



**LB-1800C**

**LB-2800C**

**LB-4000C**

# **Watermakers with Spectra Connect**

## **Installation and Operating Manual**

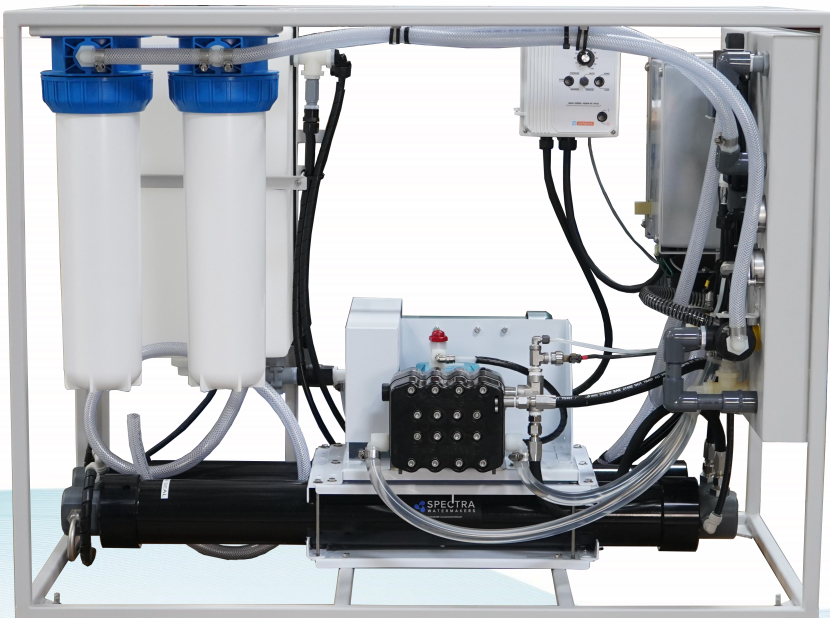

Spectra Watermakers  
Katadyn Desalination LLC.  
2220 S. McDowell Blvd. Petaluma, CA 94954  
Phone: 415-526-2780 Fax: 415-526-2787  
techsupport@spectrawatermakers.com  
www.spectrawatermakers.com  
Updated February 2023

Page Intentionally Blank

# Table of Contents

<b>Part 1</b>	
<b>Installation</b>	<b><u>Page Number</u></b>
Getting Started	5
Quick Start	6
Installation	7
Tank Level Switch Installation	12
Plumbing Diagram	15
<b>Operation</b>	
New Systems Start Up and Testing	17
Sensor Calibration	19
Networking	23
Normal Operation	25
Auto Store	29
<b>Service &amp; Maintenance</b>	
Long Term Storage Procedures	30
Maintenance	32
Oil Changes	34
Tube fitting information	35
Troubleshooting Procedures	37
Wiring Schematics	53
Bulletins	49
SP-5 Pearson Pump - 20% Exploded View	57
SP-5 Pearson Pump - 30% Exploded View	58
SP-5 Pearson Pump - 50% Exploded View	59
<b>Parts Identification</b>	60
<b>Controls</b>	
Spectra Connect Overview	40
Sensor Calibration	19
Dealer Access Settings	42

Page Intentionally Blank

# Getting Started

Please read through the complete manual before starting your installation. The system is easy to operate and maintain as long as it is installed and calibrated correctly.

Spectra Watermakers Land Based Desalination Systems are shipped pre-tested and pickled with propylene glycol for shipment. The system is ready for installation with the options specified with your order. Please unpack the system and inspect it to make sure that it has not been damaged in shipment.

Refer to the shipping list for your system to make sure you have received all of the components listed.

***We will not be held responsible for shortages that are not reported within thirty days of the ship date. Shipping damage must be reported to the carrier within 24 hours of receiving goods.***

Ensure that there is proper clearance around the system for removal of filters and system service. We recommend that there is at least 36" in front of the control panel (to allow for removal of membranes) and 24" on both sides of the watermaker.

## **LB System shipping list:**

- Spectra Watermaker in Powder Coated Stainless Steel Frame, Including:
  - Pre-filtration assembly\*\*
  - Fresh Water Flush tank\*\*
  - Inlet and Brine Discharge Service Connections\*\*
  - Spectra Connect Control Box with Main Circuit Breaker\*\*
  - Feed Valve\*\*
  - 24VDC Power Supply (for controls)\*\*

\*\* components built into frame assembly

- **Install kit;**
  - Service hoses and filter wrench
  - Handheld TDS meter
  - User's Manual
- **Optional items;**
  - Boost Pump Control Box
  - Boost Pump
  - UV Lamp
  - Pressure Regulator for feed \*\*

# Spectra Connect Quick Start Guide

When you first power up the system, you will get a warning message asking **if the system has been stored with chemicals.**

**If the system has been pickled, winterized, this is the first startup, or the condition of the system is unknown, go to COMMISSIONING or serious damage may occur.**

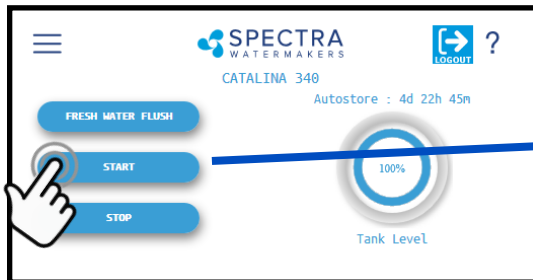

## Start

Pressing the 'Start' button once advances to the Run Mode selection screen.



## Run Mode

Select your desired Run Mode to start making water and filling your tanks. See details on Run Mode options on p. 37

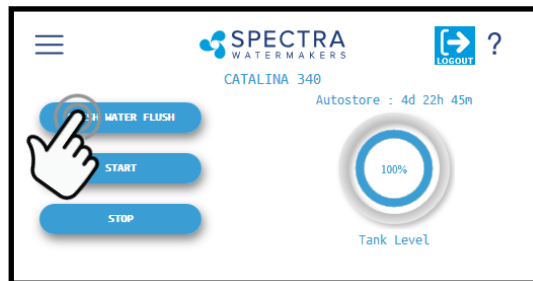

## Fresh Water Flush

Pressing the 'Fresh Water Flush' button flushes the watermaker with fresh water from the vessel's domestic water tanks. After completing the flush, Spectra Connect will automatically enter the Auto Store mode.

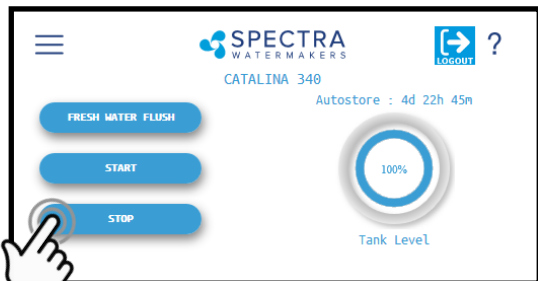

## Stop

Pressing the 'Stop' button from the Home Screen will end the Auto Store mode countdown timer and leave your watermaker in Standby mode.

## Spectra Connect Modes and Definitions

**Auto Store:** After the watermaker fresh water flushes, it will start a countdown timer that can be seen on the Home screen. The timer indicates the next programmed fresh water flush if the watermaker is not started again, or the 'Stop' button is not pressed.

**Fill Tank:** The watermaker will automatically run until the Tank Full switch in the water storage tanks closes. Once the Tank Full switch closes, the watermaker automatically fresh water flushes, then reverts to the *Auto Store* mode.

**Auto Run:** The watermaker can be set to run for a number of hours, or for a quantity of water to be produced. When the desired quantity of water is produced or the run timer expires, the watermaker will Fresh Water Flush and enter the *Auto Store* mode.

# Installation

The LB series watermakers must be protected from direct sun and weather. UV from the sun will degrade the hoses, tubes and fittings used in the system. It is recommended that the unit be under a roof in a permanent enclosure with good ventilation and drainage.

## Product Water tubing

The Product Water Outlet is a 3/4" hose barb x 3/4" female pipe thread fitting. Route the product water tube from the product water outlet fitting on the front of the unit into the top of the storage tank. Ideally the product water should fall into the tank so there is no back pressure on the product line. Install a tee in the water tank fill or tap a pipe thread into an inspection port in the top of the tank. Do not feed the water into a manifold or bottom of the tank. Make sure there is no restriction in this plumbing. **The top of the water tank must be no more than 10 feet (3M) above the top of the watermaker frame.**

**The limit on the system pumping product water is the back pressure created on the membrane when the system shuts down. If you need the unit to pump water over 10 ft. install a good quality check valve (with low cracking pressure) in the product line as this will eliminate back pressure on the membrane (from the product) when the system shuts down. Pressurized product water running back into the system can cause membrane failure.**

A product sampling tap can be installed along the tank fill hose between the outlet and the tank connection. If a 3-way valve is used as sampling tap or filling manifold is to be installed on the product water line, then an "open-before-close" type 3 way valve should be used to ensure that the product water line is never accidentally pressurized.

It is not recommended to use the watermaker as a product water delivery pump. If the product water must be delivered up hill or to a tank more than 50 feet/15M away, run it to a transfer tank and use a separate pump to move water to the desired location.

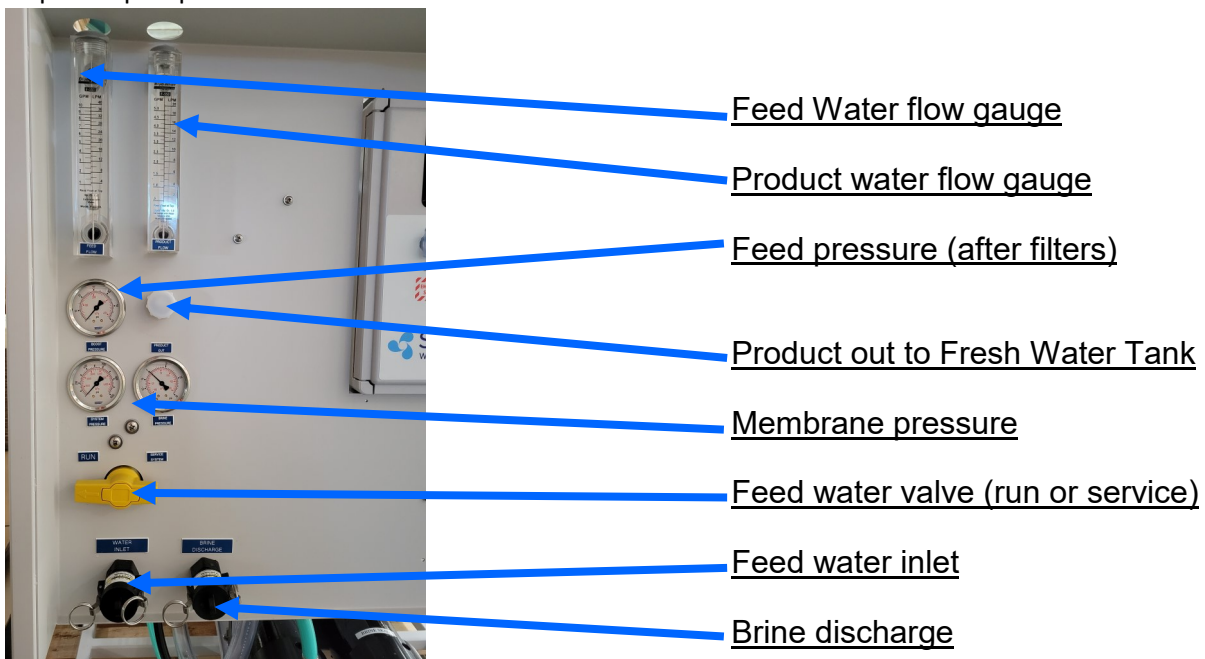

## Installation - Cont.

### Feed Water Inlet

Feed water must be supplied to the feed water inlet at a minimum pressure of 20psi (1.3bar) and a Minimum Available Flow Rate of 6.5gpm (24.5lpm). Silt density must be less than 3 SDI. If the water supply has a lot of silt in it a settling tank and or media filters are recommended.

### Brine Discharge

### Feed Water Inlet



**Note:** The Brine Discharge must go to an open drain with an air gap so there is no suction possible.

Route the Brine Discharge from the cam lock fitting back to the feed water source, or to another ecologically acceptable location. The brine flow will be roughly 4.5gpm (17 pm) and will be saltier than the feed water.

### Inlet valve

The system requires a regulated inlet pressure of 20 to 30 psi on the Boost Pressure gauge. It is recommended that the feed pressure be set as high as possible with new filters and the pump not knocking.

### Optional Pressure Regulator

The picture at right shows the feed water solenoid valve and the optional pressure regulator assembly.

**Note:** If there is no water flowing the pressure regulator may be set too high so unscrew the adjuster all the way and then adjust the feed pressure as water is flowing. Adjust the pressure regulator with a 3/8" Allan wrench so the boost pressure shown on regulator gauge is 20 to 30 psi.

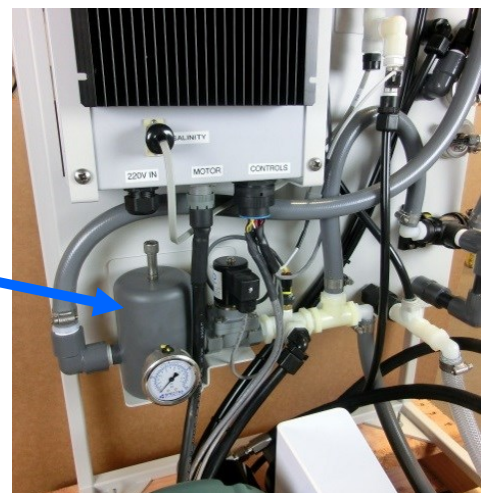
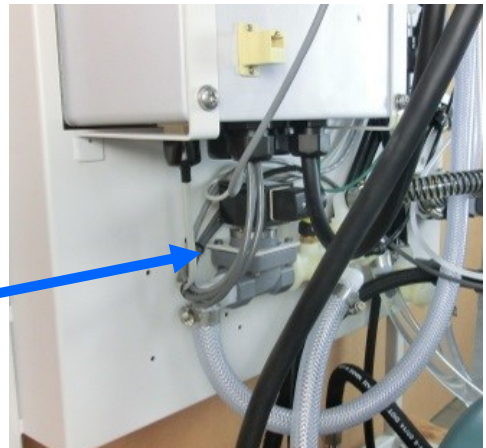



# Installation - Control System Overview

## Control Box Electrical Cables

All connections to the control box are clearly labeled next to the corresponding connector. Be sure to use a properly sized circuit breaker between the equipment and the power source. Use a length of SO cable to connect to the power source. All units use 24 VDC for the control circuits and a power supply is included in the box (on AC units).

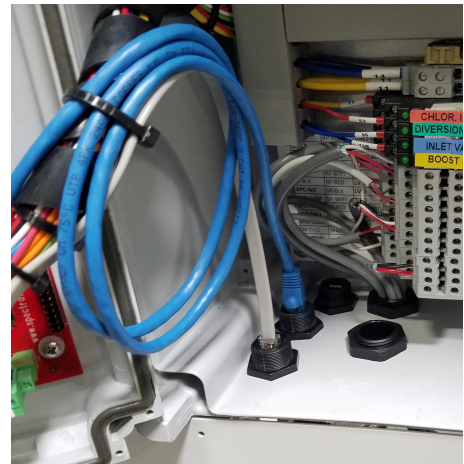

## Electrical Connections

All connections in the control box are clearly labeled next to the corresponding connector.

Cord grip for main 220V Power Cable

220V main power Din Rail Terminal

220VAC Chlorine Injector Power Terminal Block (See Wiring Diagram)

Auxiliary connections for:

- Tank level switches
- Tank level sensor
- Boost pump switch
- Media filter lock-out (N/O contact)
- Alarm (24V)

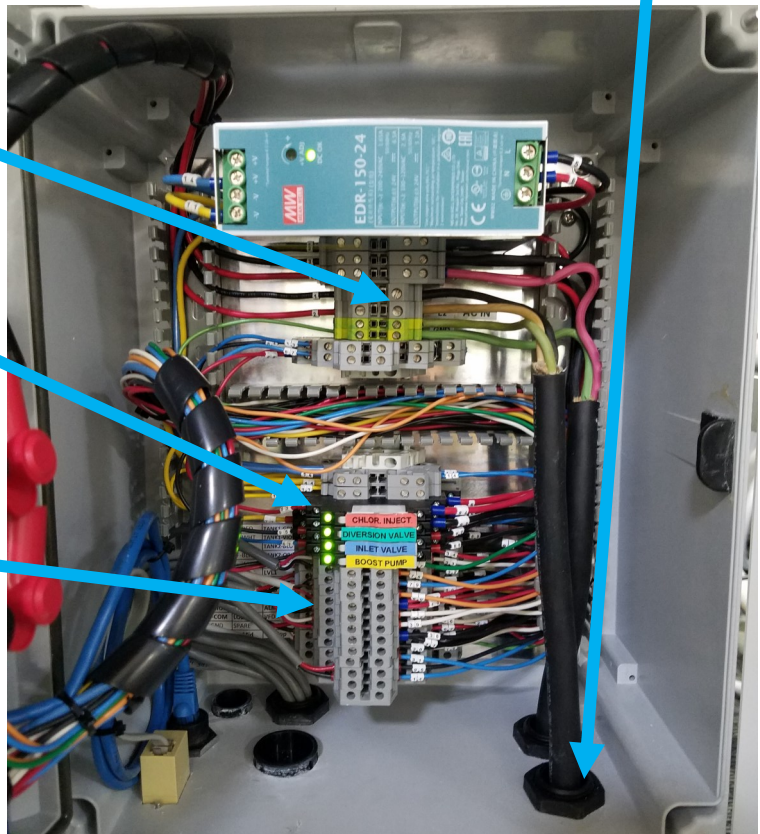

## Installation - Control System Overview

Connecting the Spectra Connect control board to an Ethernet Switch or a LAN port on your wireless router will allow the system to be controlled from any mobile device.



### Initial power-up

When power is first applied to the unit the main breaker (Emergency Shut-Off) should be in the off position. The Service toggle switch should be in the off position.

Main Breaker

Service Switch



The Run toggle switch on the speed control should be in the Auto position for both the main pump and the optional boost pump.

Note this is a Toggle Switch:

Up—AUTO  
Down—Manual



# Installation - Control System Overview

## VFD Speed controls

The VFD for the Pearson Pump is mounted for easy access. This speed control is configured for the line voltage indicated on your order and it converts this to 3 phase output which allows for speed control.

It also provides “soft start” so the motors will not draw more than their normal full load.

Systems supplied with the optional boost pump will use the same speed control which can be connected to the water maker (via the attached control cable) so it will start when the watermaker starts, or it can be operated independently.

In normal operation the toggle switch should be in the AUTO position.

Two way Toggle Switch:

Up - AUTO

Down - Manual



# Tank Switch or Tank Level Sensor Installation

## Optional Factory Supplied Tank Switches

The system can be started and stopped with tank level switches. The system will start when the low level switch opens and will then stop when the high level switch closes. There are two types of tank float switches available depending on your installation requirements. Often making an assembly as pictured below (right) is a good solution as there is only a single penetration and it can be above the high water level.

Top mounted float switch  
(Tank High Switch)  
**EL-SWT-LV**



Side mounted float switch  
(Tank Low Switch)  
**EL-SWT-SMLV**



**Use the Dealer Access settings (pg.42) to enable the tank switches**

**Tank Setup** - Enable/disable tank level sensors.

**Enable Tank Switch High** - Enable/disable tank high switch high. If this is disabled Auto Fill and Fill Tank run modes will not be available.

**Enable Tank Switch Low** - Enable/disable tank high switch low. If this is disabled Auto Fill mode will not be available. Both High and Low tank switches must be enabled for Auto Fill mode.

**Enable Tank Level 1** - Enable/disable tank level sensor 1.

**Enable Tank Level 2** - Enable/disable tank level sensor 2.

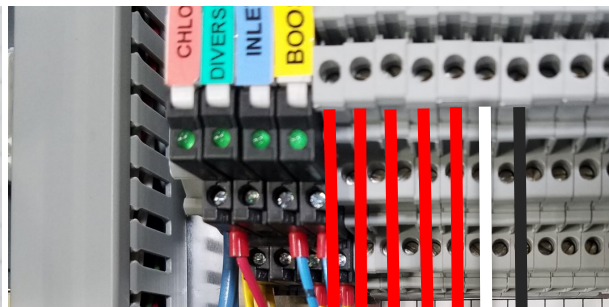
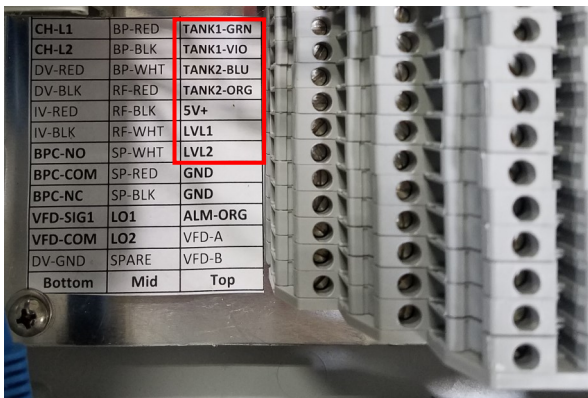

Tank Switch #1

Tank Switch #2

Tank Level Sensor

# Tank Switch or Level Sensor Installation

## Factory Supplied Tank Switches

There are two types of tank float switches available depending on your installation requirements. Often making an assembly as pictured below (right) is a good solution as there is only a single penetration and it can be above the high water level.



Top mounted float switch EL-SWT-LV



Side mounted float switch EL-SWT-SMLV

Refer to the wiring diagrams for the Terminal Block numbers for the tank level switches.

**Note:** If tank switches are not used you **must disable the tank full switch** in the system settings.

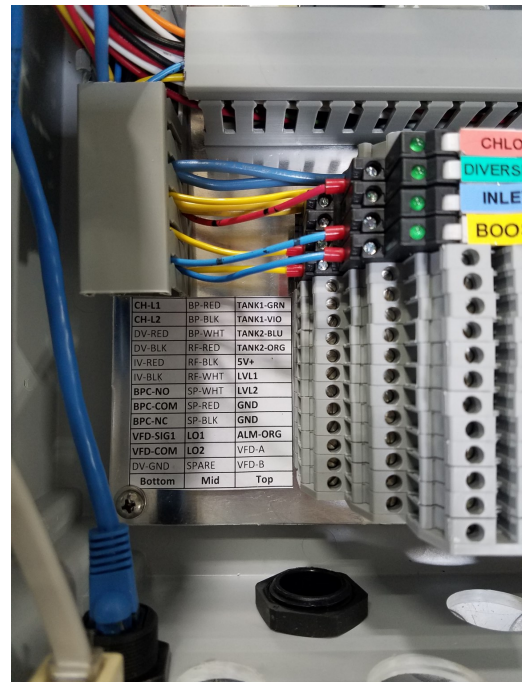

CH-L1	BP-RED	TANK1-GRN
CH-L2	BP-BLK	TANK1-VIO
DV-RED	BP-WHT	TANK2-BLU
DV-BLK	RF-RED	TANK2-ORG
IV-RED	RF-BLK	5V+
IV-BLK	RF-WHT	LVL1
BPC-NO	SP-WHT	LVL2
BPC-COM	SP-RED	GND
BPC-NC	SP-BLK	GND
VFD-SIG1	LO1	ALM-ORG
VFD-COM	LO2	VFD-A
DV-GND	SPARE	VFD-B
Bottom	Mid	Top

## Tank Level Sensor

Installing a tank level sensor (**EL-SSR-5PSI**) in the discharge line from your storage tank will allow the Spectra Connect to track the tank level. **Note:** The sensor is purely for observational data purposes, it cannot control your system in any way.

See the next page for detailed installation instructions.

## (Optional) Tank Level Sensor Installation

The optional Tank Level sensor allows even greater control of your ship's fresh water systems. This unique level monitoring system requires no holes to be drilled into your tank while measuring tank volume with greater accuracy than a standard resistive float.

Turn off the ship's domestic water system, close the fresh water supply valve at the water tank, then bleed off the pressure by opening a tap in the galley or head sink.

Install a tee in the **water supply hose at the bottom of the tank, or at the inlet to the domestic water pump**. Connect open leg of the tee to the Tank Level Sensor. Note: The tank level sensor requires a 1/4" npt connection. We recommend installing a minimum 1/2" tee, and using a reducing bushing to connect the sensor.

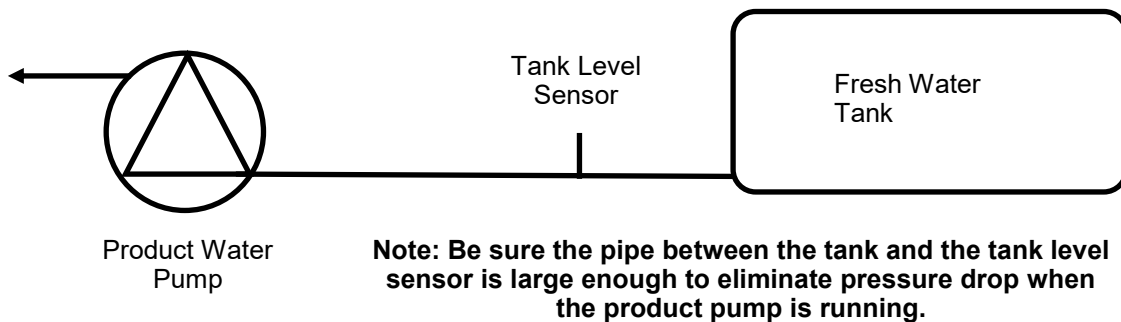

Route the 3 conductor cable back to the Spectra Connect control board at the feed pump module. Extend the wires as necessary. *If you must extend the wires beyond 50' contact the factory to ensure proper operation.*

Connect the Tank Level Sensor cables to the appropriate terminals in the Control Junction Box (pg. 10) and refer to the wiring diagram on pg.49 to identify the correct terminals. **Polarity must be maintained!**

If a 2nd Tank Level Sensor is going to be installed, it should be installed at the base of the second tank. **If monitoring 2 connected water tanks, they must be isolated from each other with a valve to read properly.**

The wiring connections for the second Tank Level Sensor are located inside the Spectra Connect control box. **See System Settings section of this manual for instructions on enabling the second Tank Level Sensor.**

**See the Tank Level Calibration (pg. 18) in the Commissioning section of this manual.**

# LB-1800-2800-4000 Plumbing Diagram

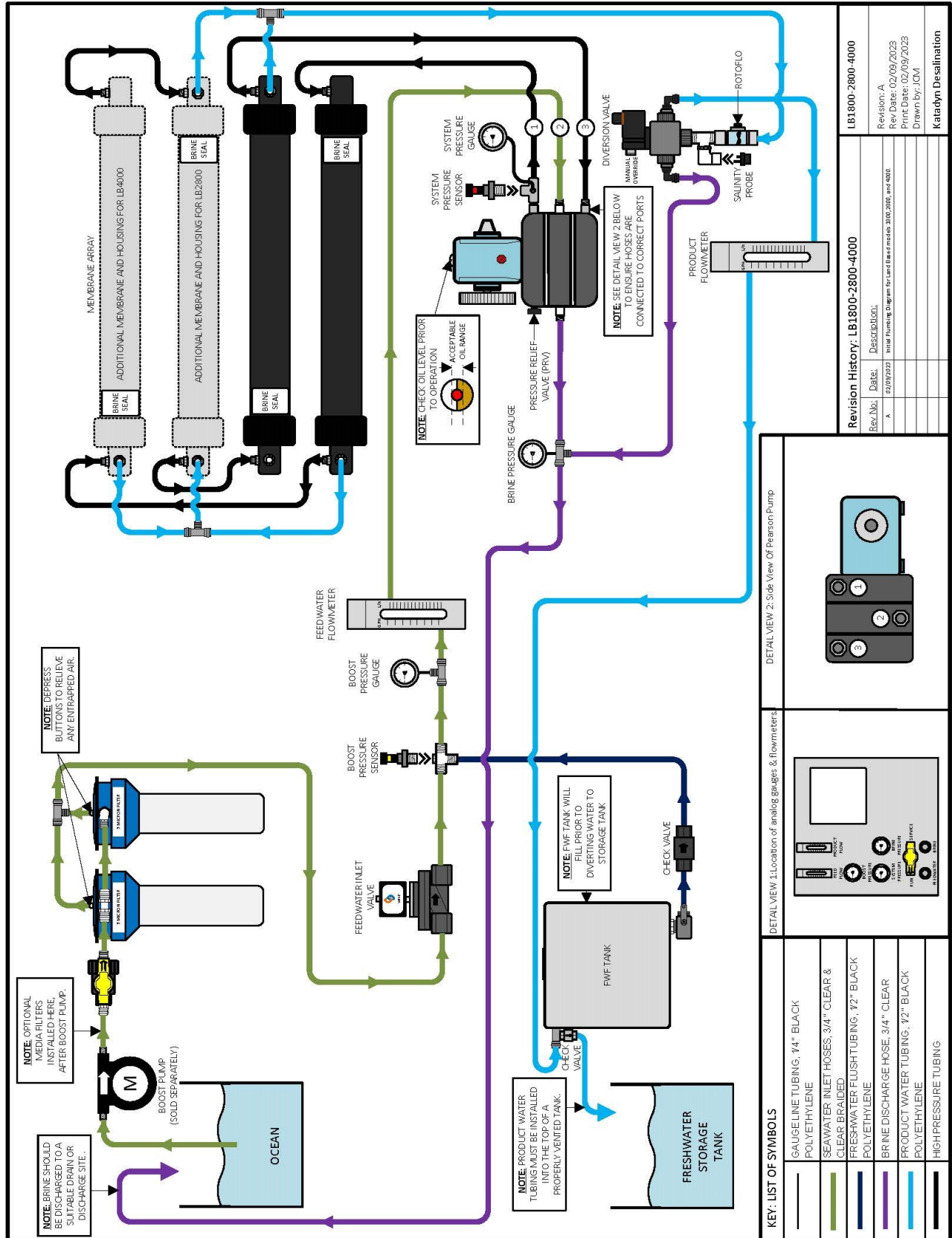

# LB-1800-2800-4000 Plumbing Diagram Cont.

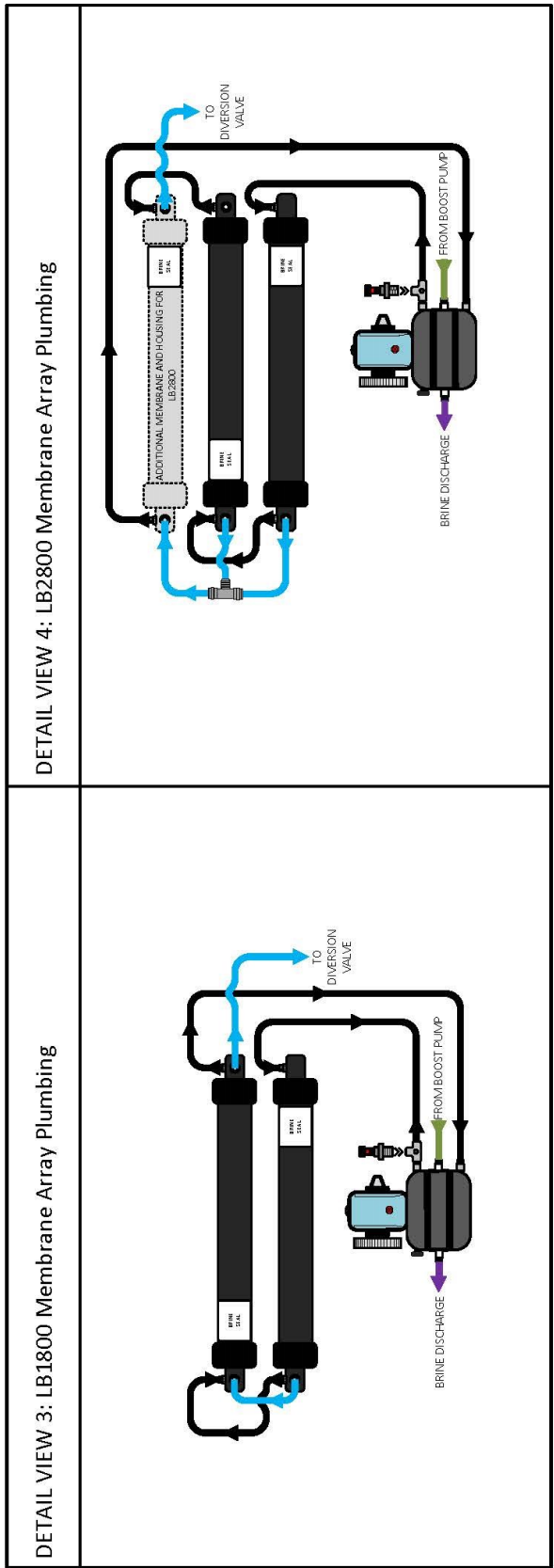



# New System Start-Up and Testing

Use this procedure when the system contains preservative or cleaning chemicals.

**Warning! Damage will occur if the system is not purged of the storage chemicals before pressurizing the system.**

## 1. First Check that:

- Brine discharge is directed to a suitable location. The brine discharge will contain a small amount of propylene glycol (non-toxic potable anti-freeze) during the purge cycle.
  - The TAPE is removed from the oil vent cap on the top of the crankcase, confirm there is oil in the crankcase.
  - Pressure Relief Valve is OPEN one full turn.
- 
- Before purging the system, be sure that the Green Tag secured by a rubber washer on the pressure relief valve is removed.

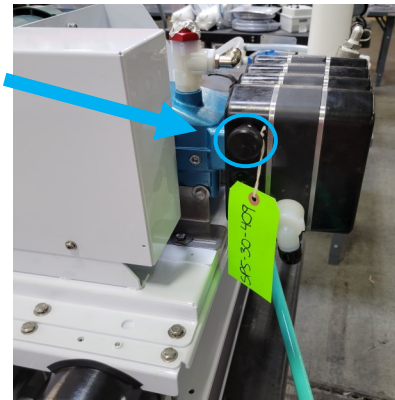
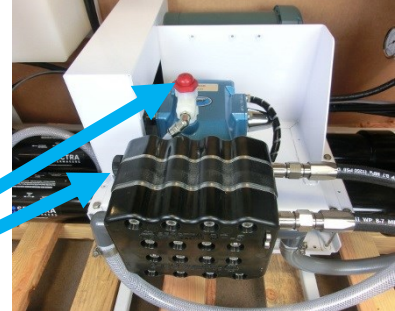

## 2. Feed flow and pressure gauges

The feed flow gauge will show feed water flowing on start-up. The Product flow gauge will not show flow until the flush tank is full.

At start-up the feed water solenoid will open and Boost Pressure gauge will show the feed pressure after the filters.



# New System Start-Up and Testing

3. Confirm the inlet valve is in the RUN position.

4. Confirm the SERVICE toggle switch on the front panel is in the OFF position, and toggle switch on the speed control is in the AUTO position



5. Turn on the power to the system and the screen will display, "Has the system been stored with chemicals?" Press 'Yes', to start the Purge sequence. **Note:** The watermaker will shut down if the pressure relief valve is left closed during the Purge mode.

Spectra Connect

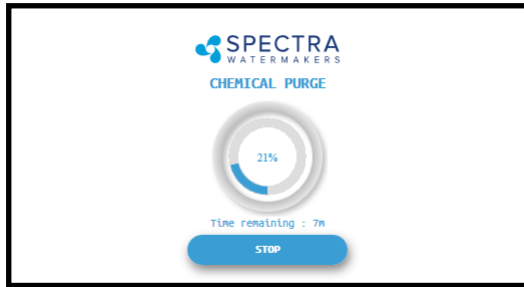

6. The system will start purging and the display will show the progress and time remaining for the purge cycle.

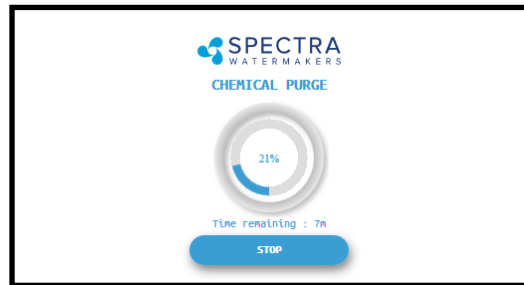

7. Note that the Filter Pressure gauge is after the electric feed valve so it will only read feed pressure when the system has been started (so the feed valve opens and shows the feed (boost) pressure, which should be about 20 psi during operation.



If the optional boost pump was included the pressure can be adjusted with the knob on the boost pump control box.



## New System Start-Up and Testing - Cont.

8. Using the buttons on top of the filter housings, bleed out the air in the filter housings until water is coming out.



9. Check the brine discharge for water flow. The system should fully prime within 60-90 seconds and all air should be out of the feed water hoses. The pump will should sound smooth and if there is any knocking adjust the feed pressure up or down until the pump is running smoothly. Note if the boost pressure drops below 10 psi, the system will alarm and tell you to check the prefilters.

**Note:** If you must stop the purge sequence for any reason, the control will default back to the beginning of the purge cycle to protect your system. If for some reason your system does not go back into purge mode after servicing your prefilters, you will need to use the menu to start the purge sequence again. To do this, push the menu button, and hit “reset”.

10. After the purge sequence the display will alarm with the message “Close pressure relief valve.” Close the valve and proceed by pressing Ok to resume the Purge Cycle running pressurized and purging the product water to drain.

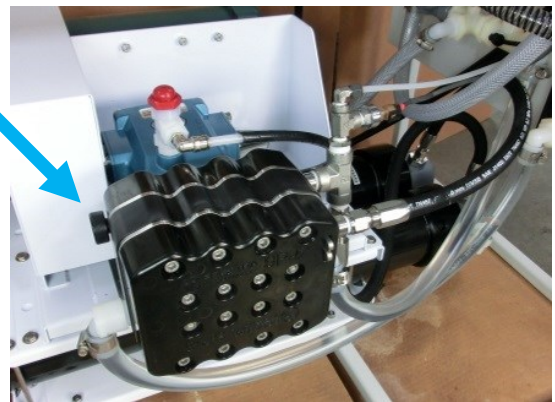

## New System Start-Up and Testing - Cont.

11. The system will now run under pressure and desalinate water. This mode diverts the product water overboard in case there is any residual chemicals in the membrane. Carefully inspect for leaks over the entire system! Shut down the system and repair any leaks you find.



12. After the Product Purge cycle completes, the system will prompt to Restart, then advance to the Main Menu. If this is a NEW INSTALLATION, continue to the Calibration Instructions to finalize the installation. If you are putting your watermaker back into service after storage or cleaning your system is now ready for use.

**If the system is stored with Propylene Glycol, additional purging time may be required if there is chemical odor to the product water, or if salinity remains high after the purge sequence. All systems are shipped from the factory stored with Propylene Glycol.**

Note that the flush tank will fill first and then product water will be diverted to your storage tank.

# Sensor Calibration

Many of the settings on your system have been pre-calibrated during standard factory testing, however, there are a few settings that will vary based on the installation conditions. **If the system has just been installed you must calibrate the Prefilter Condition graph before proceeding.**

## Prefilter Gauge Calibration

This procedure does **not** need to be done with each filter change under normal operation, it should **ONLY BE DONE IF THE FILTER CONDITION GAUGE WON'T RESET TO 100% WITH NEW FILTERS.**

1. During the calibration sequence the system will automatically start, begin to make water for several minutes and then shut itself down. *Make sure that new filters are in place before proceeding.*
2. Follow the steps in Figures 1-4 below to initiate the Calibration Sequence.



Fig. 1

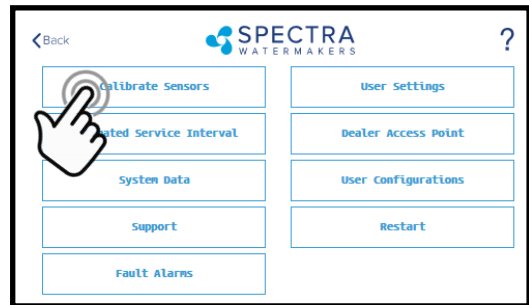
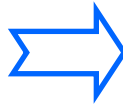

Fig. 2

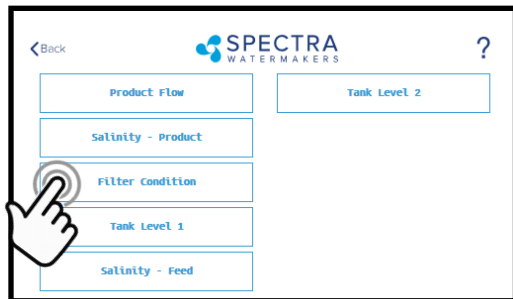
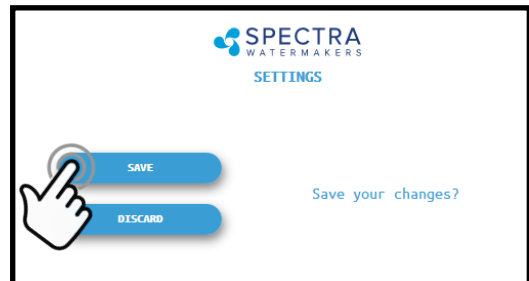

Fig. 3



Fig. 4

3. When the Calibration Sequence is complete, press the **<Back** button in the upper left corner to return to the Main Menu. *When prompted by the display, Click **Save** to make sure that the Calibration is stored in the system memory.*
4. The **Filter Condition gauge** has now been calibrated to match your installation.



# Tank Level Sensor Calibration (with optional transducer installed)

Installing the optional tank level sensor (EL-SSR-5PSI) will allow the control to display tank levels in up to two tanks. Follow the steps below to enter the calibration sequence for the optional Tank Level Sensor(s).

**The tank needs to be full to proceed with the calibration process and you need to measure the approximate height of the tank.**

1. With a full tank, press the Menu Button



2. Press the Calibrate Sensors Button

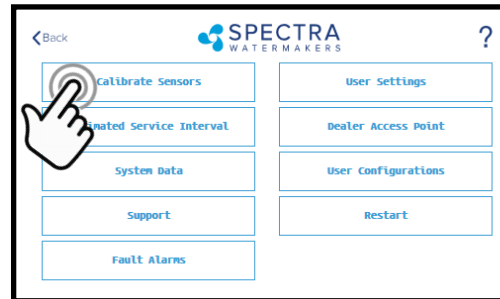

3. Press the Tank Level 1 button

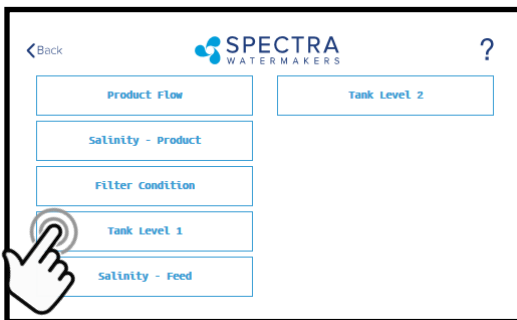

4. Press to enter the tank height

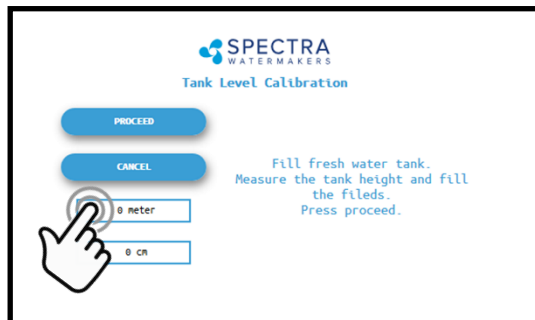

Press the Feet (Meter) field to enter the tank height in feet (meters).

Press the Inch (cm) field to enter the height in inches.

Ex: If the Tank height is 150cm:  
Enter '1' in the field labeled 'Meter'  
Enter '50' in the field labeled 'cm'

5. Enter the height

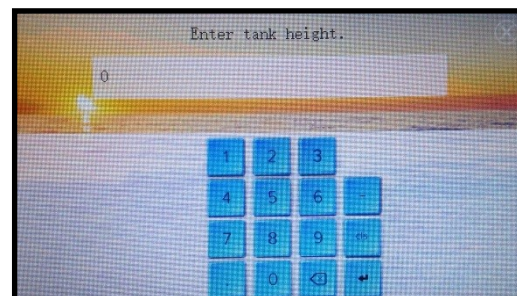

8. If the entry is correct press Proceed.

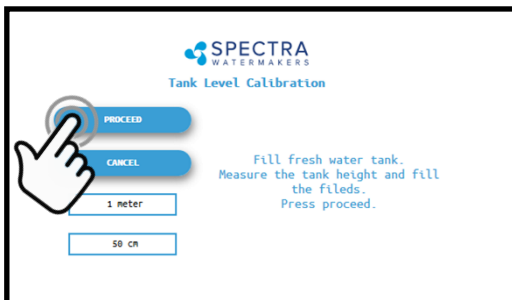

8. Press OK to save the settings

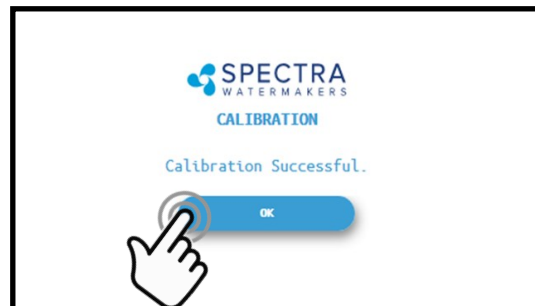

# Salinity Calibration

The Salinity probe has been calibrated at the factory during testing and is not normally required during commissioning. If the product quality is not reading accurately, follow calibration steps.

A handheld salinity meter (or other reliable device) is required to perform this calibration as you need to confirm the salinity of the product water.

1. Press the Menu Button

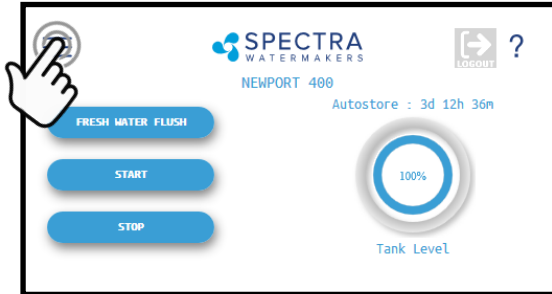

2. Press the Calibrate Sensors Button

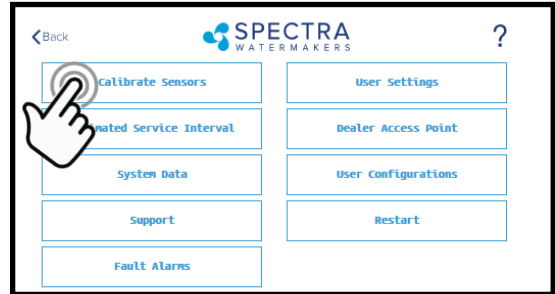

3. Press the Salinity—Product Button

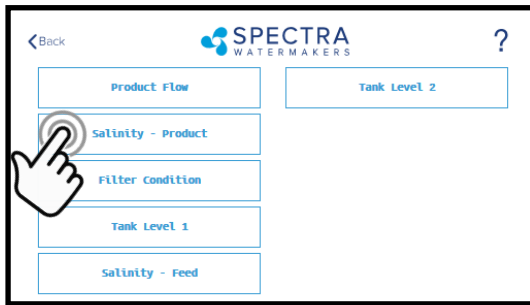

4. Press Continue to acknowledge the warning



5. Allow the salinity to stabilize for 5 minutes.

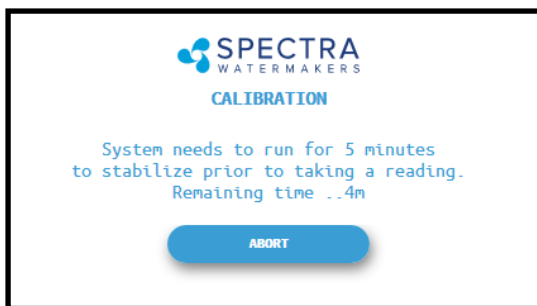

6. Press the PPM field and enter the PPM you measured. Press Proceed to save your entry.

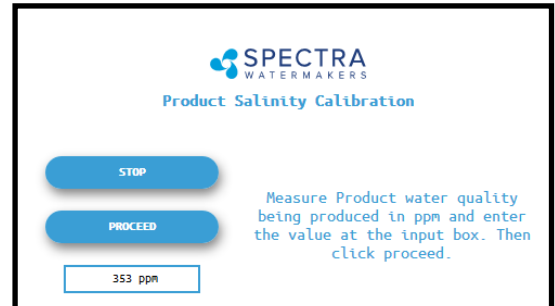

# Product Flow Calibration

The Product Flow sensor has been calibrated at the factory during testing and isn't normally required during commissioning. If the product flow is not reading accurately, confirm the product flow rate by following the Product Flow calibration steps.

1. Press the Menu Button

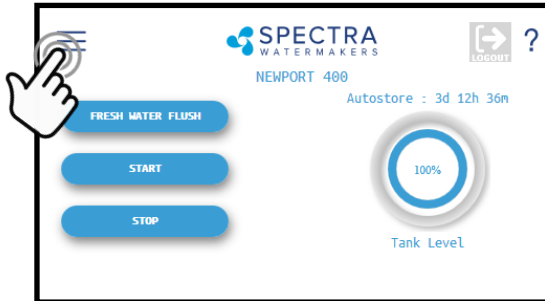

2. Press the Calibrate Sensors Button

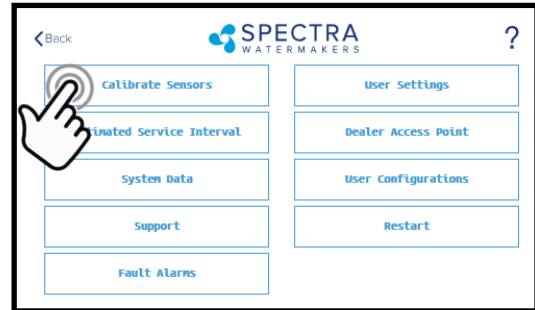

3. Press the Product Flow Button



4. Measure the product flow per the process described below, enter the numbers below and press Proceed.

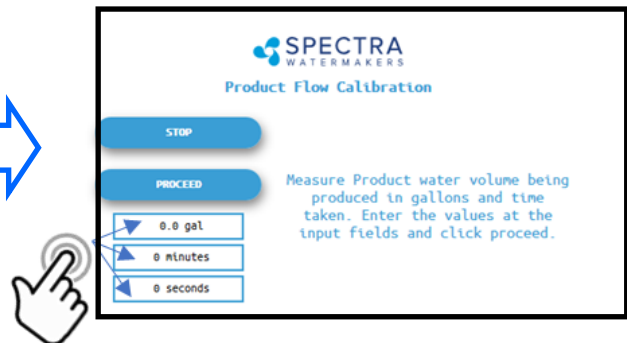

4. Allow the system to run for a few minutes to stabilize and then time in minutes and seconds, how long it takes to fill a container of a known volume.
5. Touch the 'Gal' ('Liter') field to enter the volume of the container used.
6. Touch the 'Minutes' field to enter the minutes it took to fill the container. *Only enter the minutes, ex: 3 min 15 sec should be entered as 3.*
7. Touch the seconds field to enter the seconds it took to fill the container. *Only enter the seconds, ex: 3 min 15 sec should be entered as 15.*
8. Press 'Proceed'. *You must save all changes when prompted after exiting the settings menu*



# Networking

Your Spectra Connect is equipped with state of the art networking options to allow the maximum user control in a wide variety of installations. The instructions below will help you get the most out of your Spectra Connect.

**Note:** Your Spectra Connect is only available when your device is connected to the same local network as the Spectra Connect control board. If you have difficulty connecting to your watermaker control application, double check that your device network is the same as your Spectra Connect

## Connecting to the existing Network

1. Turn power to the system off.
2. Connect a standard Cat5e or Cat6 ethernet cable from the control board located inside the feed pump module to your router or networking switch.

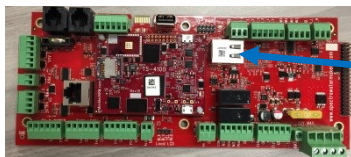

Ethernet Jack

Note: If you are connecting directly into a wireless router, **DO NOT CONNECT TO THE WLAN (Wireless Local Area Network)** ethernet port. You must connect to one of the LAN ports typically labeled 1, 2, 3, 4, etc.

3. Turn power to the system back on.
4. Follow the screen prompts below:

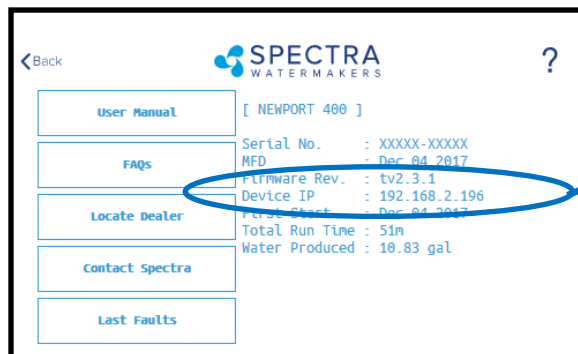
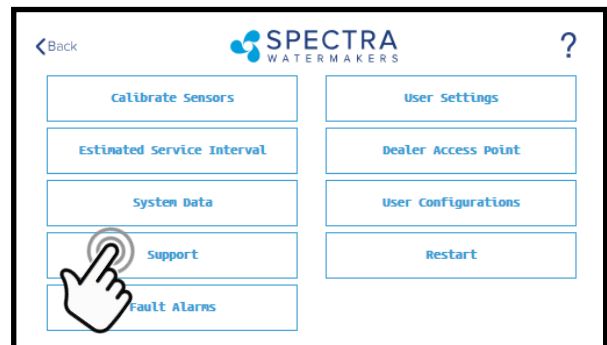
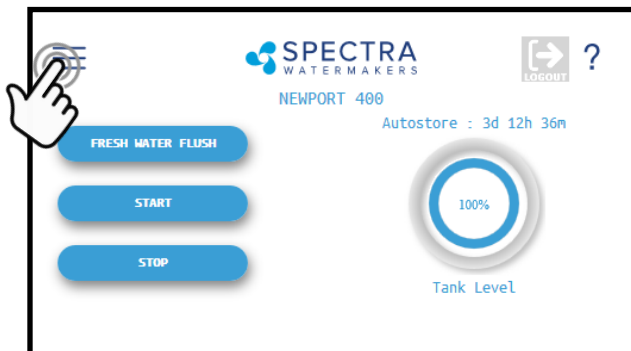

Firmware Rev. : tv2.3.1  
Device IP : 192.168.2.196  
First Start : Dec 04 2017

5. Note the 'Device IP' address shown in and record the 10 digit numerical address on the front of this manual for future reference.

## Connecting to the existing Network - Cont.

6. Connect your computer, tablet or smart phone to the local network your Spectra Connect is plugged into;

**Wired Connection:** simply plug your computer's ethernet port directly into the router or switch where you connected the watermaker.

**Wireless Connection:** make sure your device is connected to the same local wireless network as the Spectra Connect (LAN).

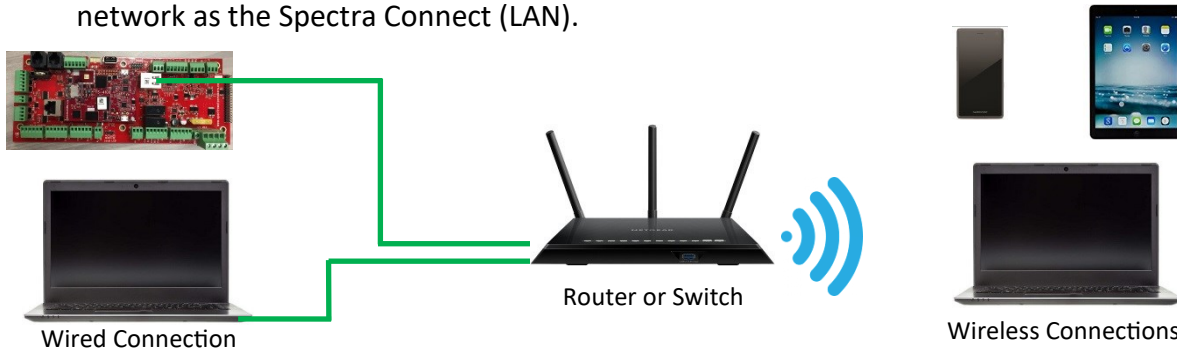

7. On the computer, tablet or smartphone, open a web browser such as Firefox, Chrome, or Safari. In the web address bar at the top, type the 'Device IP' address previously recorded. Press 'Enter'.

**Note:** Internet Explorer may not be compatible with your Spectra Connect web app. If formatting issues occur, use another browser such as Firefox, Safari, or Chrome.

Ex: Address Bar—Firefox

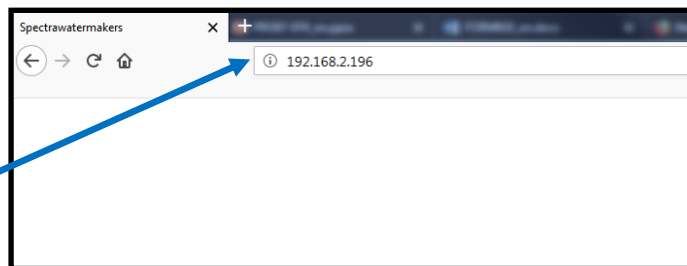

8. Your computer should now show the same image as shown on your local Spectra Connect

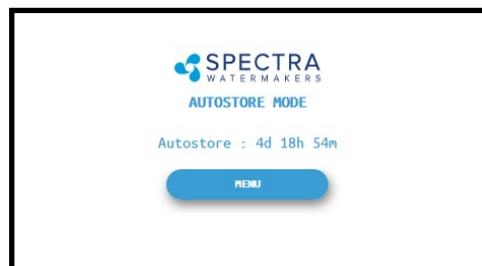

9. Your web browser is now synced with your Spectra Connect. Any buttons you press on your web browser will be controlling your watermaker.

**Caution!** If operating your watermaker from a computer, phone, or tablet, you must keep the tab open while the system is in operation and the volume turned up on your device in order to hear any audible alarm faults.

## Normal Operation

If the system has been pickled or stored with chemicals, use the New System Startup procedure.

Your watermaker will fresh water flush **after every use**. Remember that you need to run the system approximately half an hour to make enough fresh water for one flush.

1. Check to see that the inlet and brine discharge seacocks are open and the domestic pressurized water system is turned on.
2. Press the 'Start' button, then select the desired operating mode.

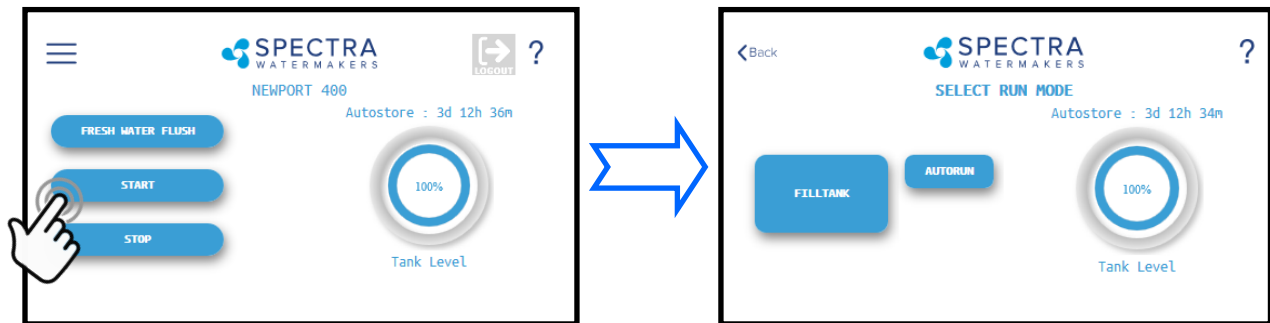

### Standard Operating Modes



3. Runs your watermaker until the Tank Full switch closes, fresh water flushes the system, then goes into 'Auto Store' mode and the Flush Interval timer starts. *This is the default mode of operation.*

-OR-



4. Gives you the option to run for a preset amount of time, or a preset volume of water to be produced. **If no tank switches are installed, and they have been disabled in the system settings, this is the only Operating Mode available.**



## Normal Operation - Cont.

5. The system will now begin the start sequence and will count down to the pump starting. Pressing 'Stop' will stop the sequence and bring you back to the Main Menu.

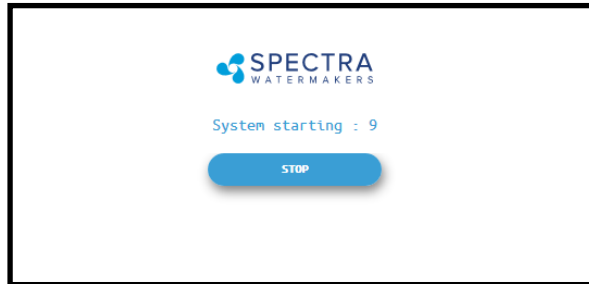

6. Once the Boost Pressure reaches the minimum threshold, the system starts operating and you will be taken directly to the Main Dashboard which shows the current status.

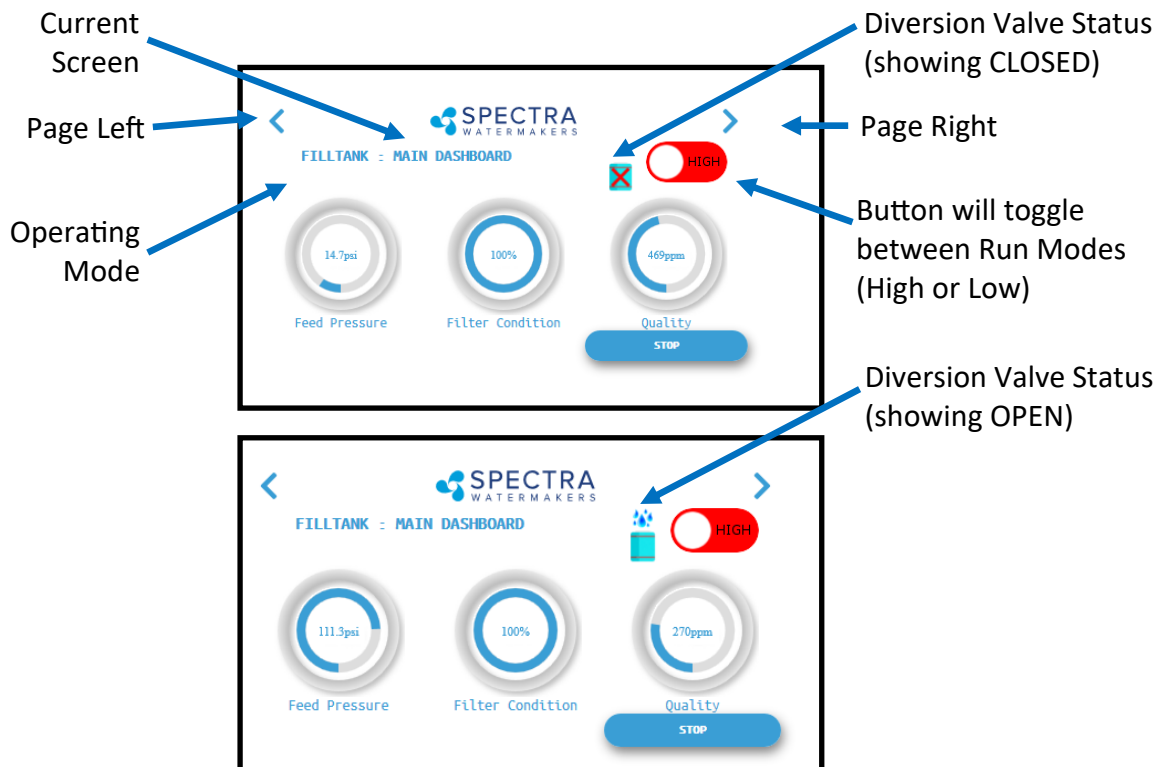

7. When the Product Water Quality is better than the programmed threshold, the Diversion Valve opens, allowing water to enter the tanks and the screen image changes.

*Verify that the system is operating according to the factory specifications detailed on p.36. See the Troubleshooting section to identify any anomalies.*

8. Pressing the < (Page Left) or > (Page Right) arrows while the system is running will scroll through the different screens with operating information for your watermaker.

## Normal Operation - Cont.

9. When the Run Cycle completes, the system will start the Fresh Water Flush cycle. If you stop the system (interrupting the run cycle) the system will also start a flush cycle.

**The system must be FRESH WATER FLUSHED AFTER EACH USE, or serious damage can occur.**

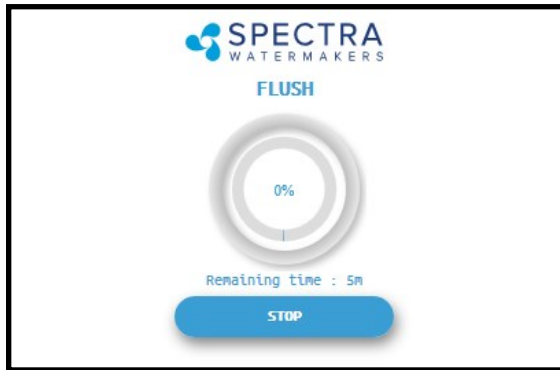

10. After Fresh Water Flushing the system will enter standby mode waiting for the next run cycle.

**Note: See pg. 26 for ways to utilize the Auto Store mode.**

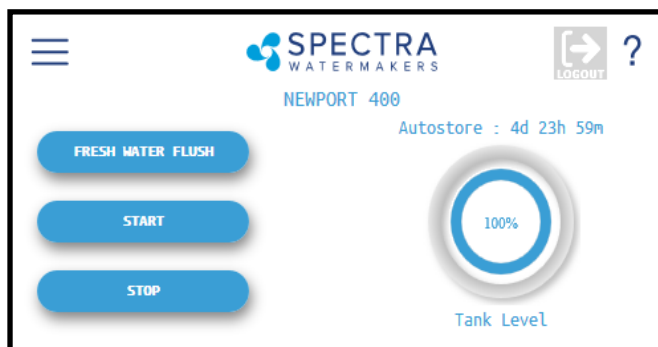

## Normal Operation - Cont.

### Other Operating Modes

#### Run Low Mode

You can toggle back and forth between Run High Mode and Run Low Mode by tapping the 'High' toggle button.

Run Low Mode may be selected to reduce power consumption, lower the membrane pressure, or prolong filter life.

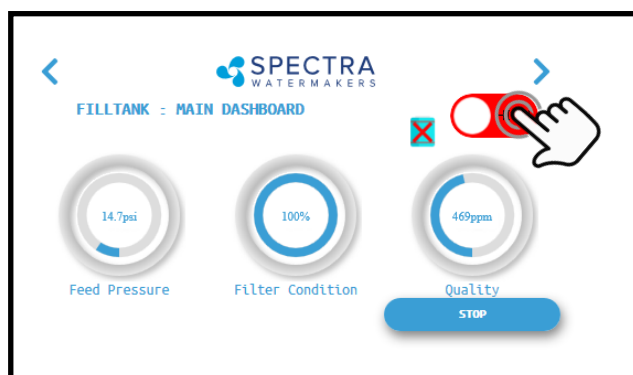

**Note:** The system will automatically drop to Low Mode when it senses high membrane pressure, or low boost (feed) pressure.

#### Auto Fill Mode

If using the Tank Low and Tank Full switches, **and both are enabled in the system settings**, then your Start Menu will allow the system to be operated in Auto Fill mode.

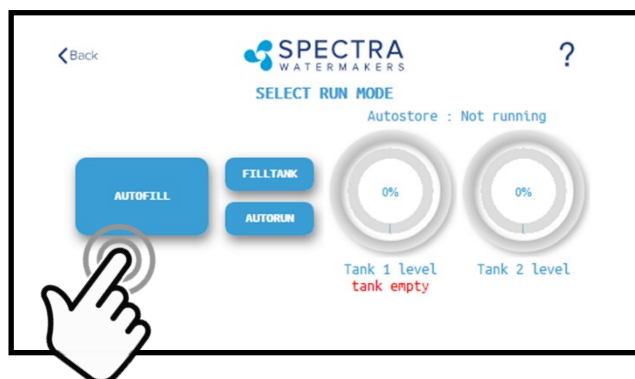

In Auto Fill Mode the Spectra Connect will automatically fill your water tank, stop itself, fresh water flush, return to Auto Store mode with the flush interval timer running, and then turn itself on again to fill the tank as soon as the water level drops below the Tank Low Switch with no additional user commands.

Additionally, if power is interrupted at any stage of operation, the Spectra Connect will return to Auto Fill mode, ensuring that your tanks will always have water.

## Auto Store

**Warning!** Proper understanding of the Spectra flush system and the fresh water system is mandatory for extended use of Auto Store.

The Auto Store function flushes the watermaker at programmed intervals. As long as the watermaker is flushed with fresh water every 5 days you need not store the system with chemicals.

- **This Land Based system comes with a flush tank that is intended to do a single flush. If your watermaker will not run every 5 days you can connect the flush tank to your pressurized fresh water system (<100psi) adding a charcoal filter if it's chlorinated so the tank is always full for flushing.**

•

**Note: If the system runs out of water the pump will be damaged.**

- Make sure the pressure relief valve on the Pearson pump is closed.
- **The system must be continually powered on during the Auto Store mode.** Turning off the power will disable the automatic fresh water flush and damage may occur.

Pushing the fresh water flush button flushes the system with fresh water and activates the auto store cycle:

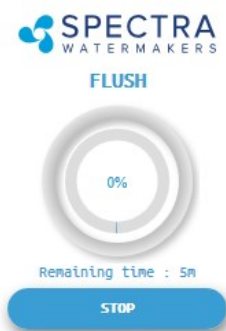

Shows Autostore: time to next flush cycle.

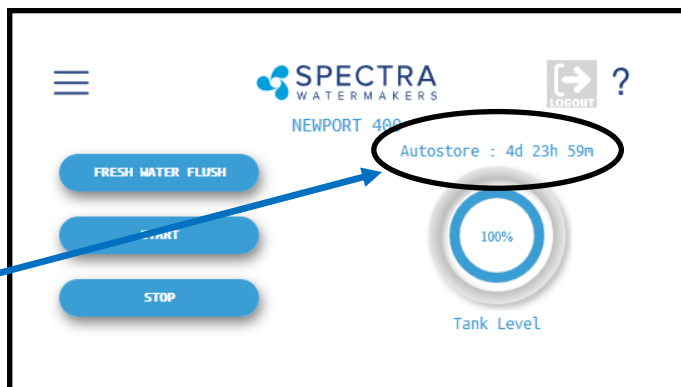
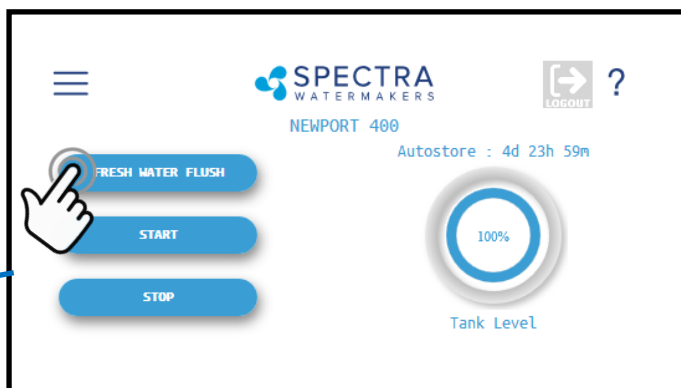

## Long Term Storage Procedures

Watermakers are best run frequently (every other day is ideal), biological growth in the membrane is the leading cause of membrane fouling. A warm environment will cause faster growth than a cold environment. The fresh water flush system will greatly reduce biological growth but may not stop it completely in certain conditions.

### **System Storage for up to 6 months, “Pickling”**

**If the system is to be left unused for more than 2 weeks**, perform the following storage procedure. The procedure introduces a chemical compound called SC-1 into the system that prevents biological growth.

**Spectra SC-1 is a special storage compound used by the US Navy. It is formulated to be compatible with the modern engineering plastics and composites in the Spectra pumps. Do not use any substitute except propylene Glycol, and SC-1 Storage Compound. SC-1 has to be mixed at a ratio of one Spectra SC-1 container to 3 gallons (12L) of fresh water to have the proper solution. An average of 6 gallons (22L) of water is already in the system which has to be figured in the mixture ratio. Then add 3 gallons of fresh unchlorinated water to the inlet, totaling 9 gallons of water volume. Three packets of SC-1 to the 9 gallons of water is considered a proper ratio of SC-1 to water.**

**Caution! Avoid contact with skin, eyes, or lungs with the storage chemical.**



# Long Term Storage Procedures

## Storage Procedure: SC-1 powdered preservative (good for 6 months):

1. Fill a bucket with 3 gallons of fresh unchlorinated water. Mix three containers of the SC-1 storage chemical compound into the water in the bucket. Note that it will take about an hour for all the chemical to dissolve.
2. Ensure that the system has been flushed in the last 5 days or run the system until the flush tank is full and do a fresh water flush.
3. Install the service hoses from the service kit on to the inlet (suction hose) and discharge (vinyl hose) connections front of the unit and put the other end in the bucket with the SC-1. Turn the yellow service valve to SERVICE.

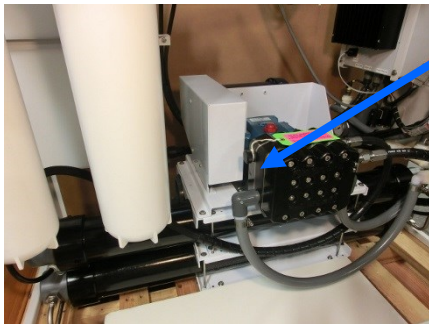

4. **Open the pressure relief valve on the high pressure one full turn.**

Run/Service Valve to SERVICE  
Discharge/Service (Vinyl Hose) Outlet  
Feed/Service Inlet (Suction Hose)



5. Close the flush tank valve (located under the flush tank)

**Handle left is run/flush**



**Right is drain**

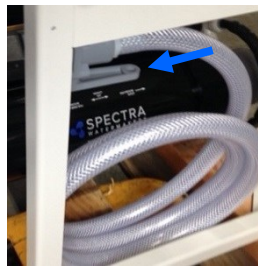

**Halfway is off**



6. Flip the Service Speed toggle switch to "on" the control box to "Service" to turn on the pump and circulate the storage chemical in the system for at least 20 minutes. Flip the service speed switch to off.

### Clean Up:

- Remove the service hoses and replace the dust caps. Turn the flush tank and run /service valves back to the 'Run' position.
- Remove the filter bowls, rinse with the storage solution and reinstall with clean dry filters. This should be a clean operation so you do not introduce bacterial into the filter bowls.
- Discard the remaining liquid in the bucket to a suitable drain.
- Turn off the power to the system.

**LEAVE THE PRESSURE RELIEF VALVE OPEN 1 FULL TURN AND LEAVE A NOTE ON THE SYSTEM SHOWING THAT IT IS FULL OF STORAGE SOLUTION AND THE DATE. ALSO MAKE A NOTE IN THE LOG BOOK.**

# MAINTENANCE

## General

Periodically inspect the entire system for leakage and chafe on the tubing and hoses. Repair any leaks you find as soon as practical. Some salt crystal formation around the Spectra-Pearson Pump blocks is normal. Wipe down any salt encrusted areas with a damp cloth.

## Prefilters

Service the prefilters as soon as the feed pressure drops 10psi from when new filters were installed.

To service the filters shut off the system including the feed water supply pump. Open the housings and discard old filters. Clean out the housing bowls, check and lubricate the O-rings with silicone grease and reassemble the housings with new 5 micron filter elements. Leave dry until next startup.

Use only Spectra approved pleated polyester filters or you may void your warranty.

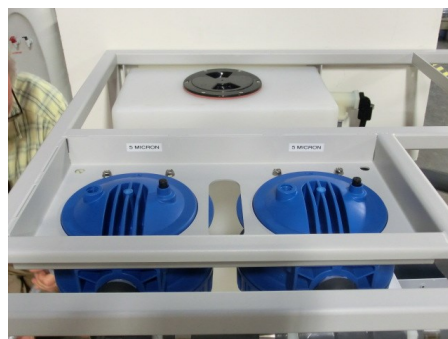

## General pump maintenance

The Boost (feed) pump requires no routine maintenance except inspection for leaks. The oil in the Pearson pump crankcase should be changed every 5000 hours or if it becomes contaminated with water (milky). Any leaks should be addresses asap. If tightening a fitting does not stop the leak, unscrewing the leaking fitting, cleaning the mating surfaces, lubricating everything with silicone grease an reassembly will often solve the problem.

## Pearson pump

As with all high pressure pumps the seals in the Pearson Pump need to be replaced from time to time. For preventative maintenance we recommend changing the seals at 2500 hour intervals (the Seal Change Manual is an appendix). The pump will likely require a complete rebuild at 10,000 hours though this can be performed when indicated by leaking or changed in recovery rate. If the recovery rate drops more than 5% the valves need to be replaced (which is part of the 10,000 hour rebuild).

# Maintenance - Cont.

## The Membranes

The membranes need to be cleaned only when membrane pressures have risen more than 10% or the product quality degrades. The leading cause of fouling is from biological growth that occurs when the system is left unused without flushing or pickling. Fouling from mineral scaling can happen during operation under certain sea water conditions, and from rust. Monitor the product salinity and feed pressure bar graphs for higher than normal readings for the conditions. Cold water can also cause high pressure. Low product flow is usually due to fouled membranes which is why we recommend that you keep a log of the basic operation parameters. If the system pressure is increasing and production is dropping off it is likely the membrane is becoming fouled.

There are two types of cleaners: acid and alkaline. The acid cleaner (SC-3) will remove mineral scaling. The alkaline cleaner (SC-2) is used to remove biological by-products, oil, and dirt particles that get past the prefilters. If membrane performance is reduced and they have not been pickled recently, cleaning with both chemicals is recommended. The acid cleaner should be used first. If the membrane fails to respond to both cleanings, this is an indication of another problem with the system, or that it is time to replace the membrane. Contact Spectra Watermakers before removing a membrane.

## Membrane Cleaning

For normal cleaning, the SC-3 Acid Cleaning Compound is used first, then the SC-2 Alkaline Cleaning Compound. If known bio-fouling is present, the SC-2 may be used first. Use hot water if possible, up to 120° F (45C) is recommended as it greatly enhances the ability of the cleaners to do their jobs.

If the history of the system is unknown or has been left “unpickled” for an extended length of time and biological growth is present, it is recommended that the system is cleaned with SC-2, using an alternate source of unchlorinated fresh water before the system is run under pressure. A simple test can be performed to see if biological growth has occurred. Before running the system, remove the prefilters and examine their condition. If the housings are full of smelly discolored water, the system was not properly stored. Install clean prefilters if they were bad. Next check the membrane. Attach the brine discharge service hose and lead to a bucket. Open the pressure relief valve one turn, and manually run the system for 30 seconds. Examine the brine water: if it’s discolored and smells bad, perform an SC-2 cleaning with an alternate source of unchlorinated water before running the system pressurized. If the brine is fairly clean, the system can be purged, run normally, and checked for performance. Clean the membranes only if performance is reduced.

# Oil Changes

## GEARCASE LUBE OIL

Use only 5W-30 synthetic oil in Spectra-Pearson Pump crankcase. Do not overfill the crankcase with oil. Check oil condition and level frequently. The oil should be changed every 5000 hours of operation or annually, whichever comes first.

The Spectra – Pearson Pump comes mounted on a CAT™ crankcase. **Inspect the oil level and condition often.**

The oil in the crankcase should be changed every 5,000 hours or when the oil appears milky. Note that if the oil appears milky it is time to change the seals as water is getting into the crankcase from the pump head. There is an inspection window on the back side of the crankcase that will show the oil level and condition.

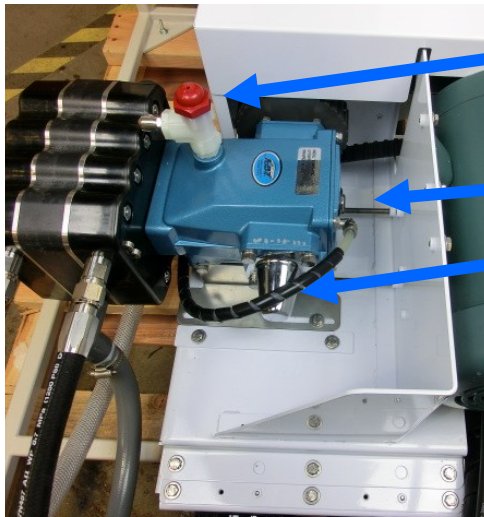

Vented Oil Cap

Inspection Window

Drain tube

Push in collar on fitting and pull out drain tube

Route drain tube so oil will drain into an appropriate container

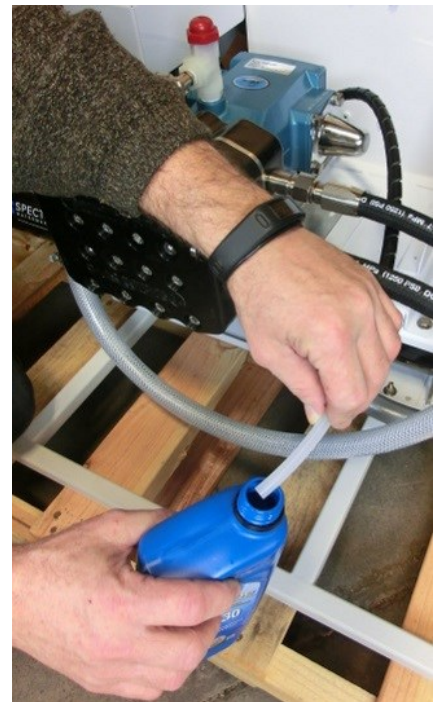

## CHANGING THE OIL

1. The oil will drain better if it is warm, after the system has been running for a few hours.
2. Disconnect the drain Tube from the (push-to-connect) fitting by pushing the collar in and pulling the tube out. See instructions on pg.33
3. Replace drain tube and refill with 1 pint (450ml) 5W-30 Synthetic oil.

Please dispose of used oil responsibly.

# Parker - Black Tube Fittings

## Fast & Tite® Thermoplastic Fittings

Fast & Tite® fittings are the most complete line of plastic fittings for thermoplastic tubing in the industry.

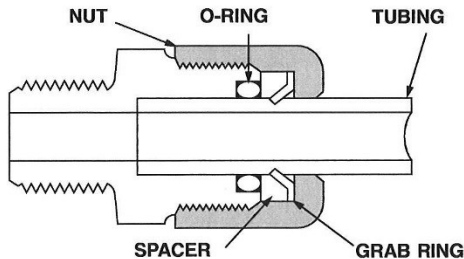

Fast & Tite® thermoplastic tube fittings from Parker will prove to be the answer to your tubing connector needs. Patented Fast & Tite® fittings install in seconds without tools and provide a tight, sure, leak proof seal without clamps or adjustments. A unique 302 stainless steel grab ring for tube retention, coupled with a Nitrile O-Ring for positive seal, assures good tube connection with only hand tight assembly. A plastic grab ring is also available upon special request. Vibration or tube movement will not break the seal and cause leakage. Preassembled in either highly inert polypropylene, or strong, durable nylon, Fast & Tite® fittings are the answer to full flow thermoplastic tubing system requirements.

When necessary, Fast & Tite® fittings can be disassembled by hand for fast system drainage. Fittings are completely reusable.

Parts are easily replaced. O-Rings are standard size and universally available. (For applications requiring other than Nitrile O-Rings, consult your Fast & Tite® distributor.)

Use Fast & Tite® fittings with Parker Parflex tubing or other plastic, glass or metal tubing for low pressure or vacuum lines up to the pressure limits shown below.

Fast & Tite® fittings meet FDA and NSF-51 requirements for food contact.

### Working Pressures for Fast & Tite® Fittings

Tube O. D., in.	Air-Oil-Water Pressure in PSI		
	Up to 75°F	76° to 125°F	126° to 175°F
1/4	300	300	300
5/16	300	300	300
3/8	250	250	150
1/2	200	200	150
5/8	150	100	50

Ratings are based on use with copper tubing, and in all cases represent the maximum recommended working pressure of the fitting only. Working pressures (vs. temperatures) of other types of tubing may limit the tube and fitting assembly to pressures lower than shown above. Consult factory for recommendations on applications other than shown above.

### Temperature Range:

Black/White Polypropylene: 0°F (-18°C) to +212°F (+100°C)  
White Nylon: -40°F (-40°C) to +200°F (+93°C)

## Fast Assembly

### Step 1.

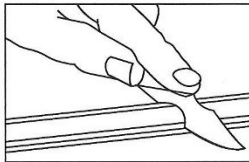

Cut the tube squarely and remove any burrs.

### Step 2.

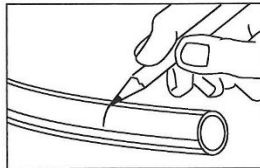

Mark from end of tube the length of insertion. (See table below)

Tube O.D. (in.)	Insertion Length with Tube Support (in.)	Insertion Length without Tube Support (in.)
1/4	5/8	9/16
5/16	5/8	9/16
3/8	13/16	3/4
1/2	7/8	13/16
5/8	1	15/16

### Step 3.

Loosen nut on fitting until three threads are visible. Fittings for glass tubes must be disassembled and the grab ring removed.

### Step 4.

Moisten end of the tube with water. Push the tube **Straight** into fitting until it bottoms on the fitting's shoulder. Tighten nut by hand. Additional tightening should not be necessary, but 1/4 additional turn may be added if desired. **Do not overtighten** nut as the threads will strip and the fitting will not function properly. A proper assembly will not show the insertion mark extending beyond the nut. If the insertion mark is visible, then steps 1 thru 4 must be repeated.

### Step 5.

When using clear vinyl tubing or urethane tubing, it is necessary to use a **TS** tube support. Disassemble the fitting and place the nut, grab ring, spacer and tube support, in that order on the tube. Locate the grab ring at the insertion mark as shown. Seat the O-ring in the body, then proceed with Step 4.

**Note:** Provide adequate fail-safe mechanisms such as leakage detection sensors, automatic shut-off controls or other industry and code appropriate fail-safe devices in the design of your water-handling appliance to protect against personal injury and property damage.

Plastic fittings containing an o-ring that are used in water applications should be replaced at least every five years or more frequently depending on the environment and severity of the application.

# John Guest Super Speedfit Fittings

## How Super Speedfit Works

To make a connection, the tube is simply pushed in by hand; the unique patented John Guest collet locking system then holds the tube firmly in place without deforming it or restricting flow.

### Materials of construction

**Super Speedfit** fittings are made up of three components:

**Bodies** are produced in an acetal copolymer or polypropylene.

**'O' rings** are Nitrile rubber or EPDM.

**Collets** are produced in acetal copolymer or polypropylene with stainless steel teeth.

## How to make a connection

Cut the tube square

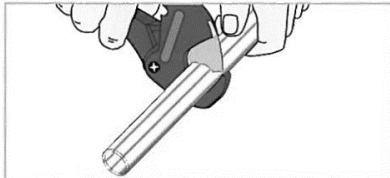

Cut the tube square and remove burrs and sharp edges. Ensure the outside diameter is free of score marks. For soft or thin walled tube we recommend the use of a tube insert

Push up to tube stop

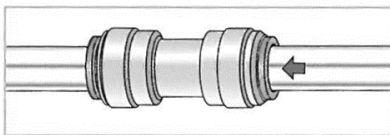

Push the tube into the fitting, to the tube stop.

Pull to check secure

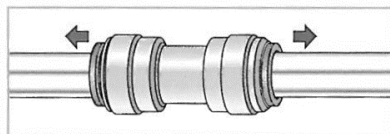

Pull on the tube to check it is secure. Test the system before use.

## Grips before it seals

'O' ring provides a leakproof seal

The Collet (gripper) has stainless steel teeth which hold the tube firmly in position while the 'O' ring provides a permanent leakproof seal.

Stainless steel teeth grips the pipe

Collet

## To disconnect

Push in collet and remove tube

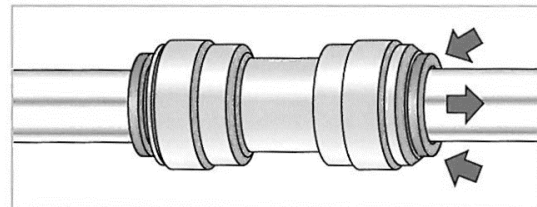

To disconnect, ensure the system is depressurized, push the collet square against the fitting. With the collet held in this position the tube can be removed.

# Troubleshooting Spectra Connect Alarms

SYMPTOMS	PROBABLE CAUSE	REMEDY
Pump runs constantly, will not turn off	<ul style="list-style-type: none"> <li>• Toggle switch on motor speed control or the Service Speed switch is on</li> <li>• Speed Control damaged</li> </ul>	<ul style="list-style-type: none"> <li>• Turn switch on motor speed control to AUTO, Service speed to off</li> <li>• Replace Speed Control</li> </ul>
Pump runs with loud noise	<ul style="list-style-type: none"> <li>• Low or high Boost pressure</li> <li>• Intake blocked</li> <li>• Air in system</li> </ul>	<ul style="list-style-type: none"> <li>• Adjust Boost pressure</li> <li>• Check sea strainer for leaks</li> <li>• Check fresh water flush module for leaks</li> <li>• Re-prime system (restart)</li> <li>• Confirm voltage at Boost Pump, check wiring connections.</li> </ul>
No lights or display, system does not operate	<ul style="list-style-type: none"> <li>• Display has gone to sleep</li> <li>• Remote display not connected</li> <li>• No power to control box</li> </ul>	<ul style="list-style-type: none"> <li>• Touch the screen to wake it up</li> <li>• Check display cable connections at back of display and at control box</li> <li>• Check and reset main DC supply breaker</li> <li>• Check for voltage control box, check 20A fuse on control board.</li> <li>• Try manual switch on control box: If pump runs, then control or display may be defective</li> </ul>
Display activates, but pump will not run	<ul style="list-style-type: none"> <li>• Loose or broken pump wire connection</li> <li>• Tanks are full (if equipped with tank switch)</li> <li>• Speed control overheated</li> </ul>	<ul style="list-style-type: none"> <li>• Check wiring at terminal block inside control box</li> <li>• Check tanks– system cannot be started if tanks are full.</li> <li>• Improve cooling</li> </ul>
System runs, no product water delivered to water tanks, Product volume gauge good, Diversion valve shows activated on display	<ul style="list-style-type: none"> <li>• Diversion valve inoperative or wiring fault.</li> <li>• Disconnected or broken product tubing</li> <li>• Diversion valve plunger stuck</li> </ul>	<ul style="list-style-type: none"> <li>• Check wiring at diversion valve and inside control box</li> <li>• Check product tubing</li> <li>• Exercise diversion valve by pressing the manual button top, retest.</li> <li>• Replace diversion valve.</li> </ul>
System runs, no product water delivered to water tanks, Product volume gauge good, Diversion valve shows deactivated on display	<ul style="list-style-type: none"> <li>• Poor product water quality diversion valve open</li> <li>• Salinity probe out of calibration or defective, bad cable</li> <li>• Chlorine damage to membranes</li> <li>• Pressure relief valve partially open</li> </ul>	<ul style="list-style-type: none"> <li>• Check for low feed pressure</li> <li>• Check for leaks at high pressure hoses</li> <li>• Test product water with hand-held tester– if over 500 PPM for 1 hour, see ‘Poor Product Quality’ on p.50</li> <li>• Close pressure relief valve</li> </ul>

## Troubleshooting Spectra Connect Alarms

SYMPTOMS	PROBABLE CAUSE	REMEDY
<p>“System Stalled” alarm is caused by the roto-flow not reading properly, if no product flow the system alarms “System Stalled”</p>	<ul style="list-style-type: none"> <li>• Pressure relief valve open</li> <li>• Intake thru-hull closed</li> <li>• Airlocked system</li> <li>• No signal from Rotoflow meter</li> </ul>	<ul style="list-style-type: none"> <li>• Close pressure relief valve</li> <li>• Check thru-hull</li> <li>• Purge air</li> <li>• Check wiring, confirm roto-flow is spinning, clean or replace Rotoflow meter</li> </ul>
<p>“High Pressure”</p>	<ul style="list-style-type: none"> <li>• Blocked brine discharge or product line</li> <li>• Fouled membrane</li> </ul>	<ul style="list-style-type: none"> <li>• Check brine discharge</li> <li>• Clean membrane</li> </ul>
<p>“Re-starting”</p>	<ul style="list-style-type: none"> <li>• No signal from Rotoflow meter at startup.</li> <li>• System airlocked</li> </ul>	<ul style="list-style-type: none"> <li>• See remedy above for “system stalled”</li> </ul>
<p>“Service Prefilter”</p>	<ul style="list-style-type: none"> <li>• Clogged filters</li> <li>• Loose or defective pressure sensor wires</li> </ul>	<ul style="list-style-type: none"> <li>• Install new filters</li> <li>• Check sensor wiring</li> <li>• If the error persists, follow Prefilter Calibration instructions.</li> </ul>
<p>“Poor water quality”</p>	<ul style="list-style-type: none"> <li>• High product water salinity</li> <li>• Chlorine damage to membranes</li> <li>• Defective salinity probe or cable, cable disconnected</li> </ul>	<ul style="list-style-type: none"> <li>• Check for low feed pressure</li> <li>• Check for leaks at high pressure hoses</li> <li>• Remove and clean probe contacts. Check calibration</li> <li>• Check cable connections</li> <li>• Clean membrane</li> </ul>
<p>“Can’t Connect to Water-maker from Web Browser”</p>	<ul style="list-style-type: none"> <li>• Device (phone/tablet/computer) not connected to same network</li> <li>• Router/Switch turned off</li> <li>• Watermaker turned off</li> <li>• Connecting to wrong web address</li> </ul>	<ul style="list-style-type: none"> <li>• Check the wireless network on your mobile device or computer</li> <li>• If using a wired connection, confirm you are connected to the same network.</li> <li>• Make sure Router/switch has power.</li> <li>• Restart Router/Switch</li> <li>• Make sure watermaker is powered on</li> <li>• Confirm Device IP address matches address typed into browser</li> </ul>



# Troubleshooting Spectra Connect

SYMPTOMS	PROBABLE CAUSE	REMEDY
Device IP in Support Menu reads 'NIL'	<ul style="list-style-type: none"> <li>• Control board not connected to router or switch</li> <li>• Control board not receiving IP address from router or switch</li> </ul>	<ul style="list-style-type: none"> <li>• Connect the control board to a router or switch according to the Networking instructions</li> <li>• Cycle power on the water-maker with the network cable connected</li> </ul>
Tank Level not accurate	<ul style="list-style-type: none"> <li>• Tank Level not calibrated</li> <li>• Domestic water pump running</li> <li>• Water tanks sloshing while underway, no baffles in tanks</li> <li>• Tank sensor failed</li> </ul>	<ul style="list-style-type: none"> <li>• Calibrate tank level according to calibration instructions</li> <li>• Stop domestic water pump and check tank level</li> <li>• Re-check tank level accuracy while vessel in in port and sea state is calm</li> <li>• Replace sensor</li> </ul>
Tank Level shows ' ! '	<ul style="list-style-type: none"> <li>• Tank Level sensor disabled in Settings</li> </ul>	<ul style="list-style-type: none"> <li>• Verify tank level sensor is installed, and enable the tank level sensor</li> </ul>
Power suddenly drops out and watermaker restarts	<ul style="list-style-type: none"> <li>• Electrical short, or failed boost pump</li> <li>• Electrical short, or failed solenoid valve</li> <li>• Electrical short, or failed pressure sensor</li> <li>• Electrical short, or failed speed control</li> <li>• Electrical short, or failed salinity probe</li> </ul>	<ul style="list-style-type: none"> <li>• Disconnect boost pump wires from control board and cycle power. Check boost pump for electrical short.</li> <li>• Replace Boost Pump</li> <li>• Disconnect solenoid valves from control board and check valve for a short.</li> <li>• Replace valve</li> <li>• Disconnect speed control and cycle power. Check speed control for electrical short.</li> <li>• Replace Speed Control</li> <li>• Disconnect salinity probe wires from control board and cycle power.</li> <li>• Replace Salinity Probe</li> </ul>

## Spectra Connect Settings

Your new Spectra Connect is designed to make your watermaker easier than ever to operate, maintain and enjoy. This section will guide you through some of the more advanced settings options available.

**Always use caution when changing any factory default settings, as serious damage can occur.**



The Spectra Connect automatically monitors the operation of the system to ensure a long and trouble-free service life. If an operating parameter changes, the Connect can switch operating modes, shut itself down, or automatically store itself in order to protect your watermaker.

It includes advanced calibration sequences to make proper setup and maintenance of your watermaker easier than ever.

The onboard clock feature allows for temporary power interruptions without detrimental effects on the system. In some cases your watermaker will continue to function in its last known operating state.

The Spectra Connect has built in data logging, allowing for easy access to historical operating data—which can indicate a wearing component or spares to be carried along before a failure occurs.

Built in warnings for preventative maintenance automatically alert a user of pending maintenance items, helping to keep your watermaker's up-time to 100%! Advance warnings are pre-programmed for Prefilter Life, Pump rebuilds, membranes, Z-Ion reactor rod life, and carbon filter life. These warnings are resettable, allowing you to perform the maintenance before a catastrophic failure, then reset the interval—so you're always on top of the maintenance cycle!

## Spectra Connect Settings - Cont.

### User Settings

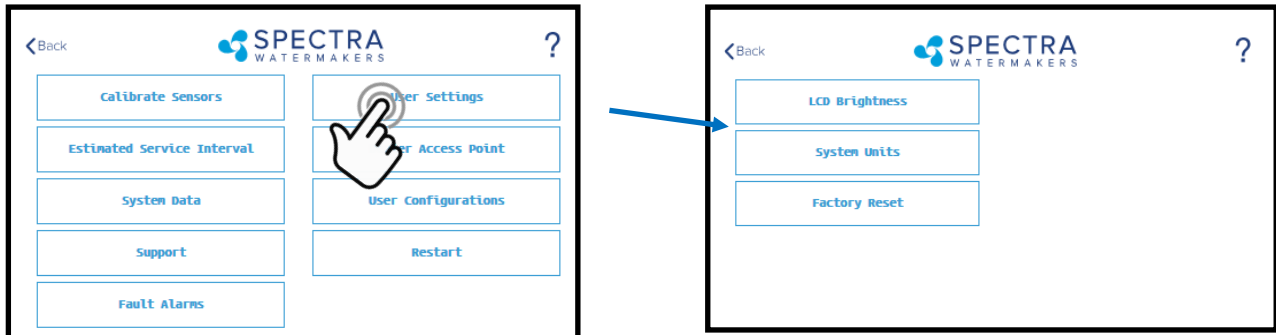

**LCD Brightness:** Set brightness of the hardwired display(s) from 10 -100%

**System Units:** Change from US Standard units to Metric

**Factory Reset:** Resets any changed parameters a user has made back to the factory defaults for that configuration.

### Fault Alarms

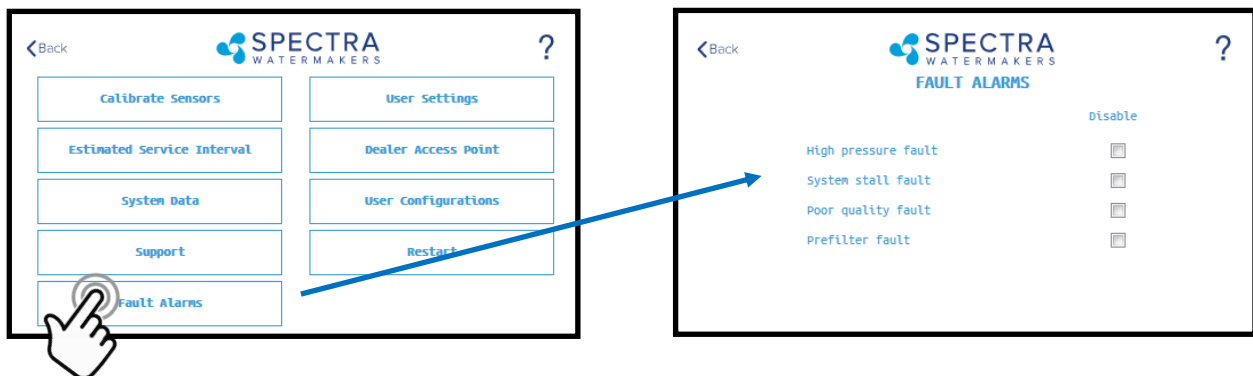

**CAUTION! Never disable a Fault Alarm without being certain that the issue is with a bad sensor. Disabling a fault and running the system can cause serious damage or injury.**

**High Pressure Fault:** Disables the 'High Pressure' shutdown fault in the event of a feed pressure sensor failure.

**System Stall Fault:** Disables the 'System Stalled' shutdown fault in the event of a failed rotoflow sensor. System stalled alarms occur when the control board does not sense any product water being produced, and shuts down to protect the pump from running dry.

**Poor Quality Fault:** Disables the 'High Salinity' shut down fault in the event that the salinity probe has failed or cannot be calibrated within range. **NOTE: The diversion valve will always be active when this fault is disabled. ALWAYS VERIFY PRODUCT QUALITY BEFORE DRINKING. Serious health risks may occur.**

**Prefilter Fault:** Disables the 'Service Prefilter' shut down fault in the event that the boost pressure sensor has failed or cannot be calibrate within range. **CAUTION: Permanent damage to the feed pump can occur if this fault is disabled, use caution when operating this system with this fault disabled.**

# Dealer Access Point - Settings

## Dealer Access Settings

It is highly recommended that users consult with a factory trained technician before altering any settings behind the 'Dealer Access Point'. **Changing this settings without understanding the full effect of each change can void the warranty of your system, and cause irreparable damage.**

**If any settings are inadvertently changed, they can be reverted back to the defaults by using the 'Factory Reset' feature.**

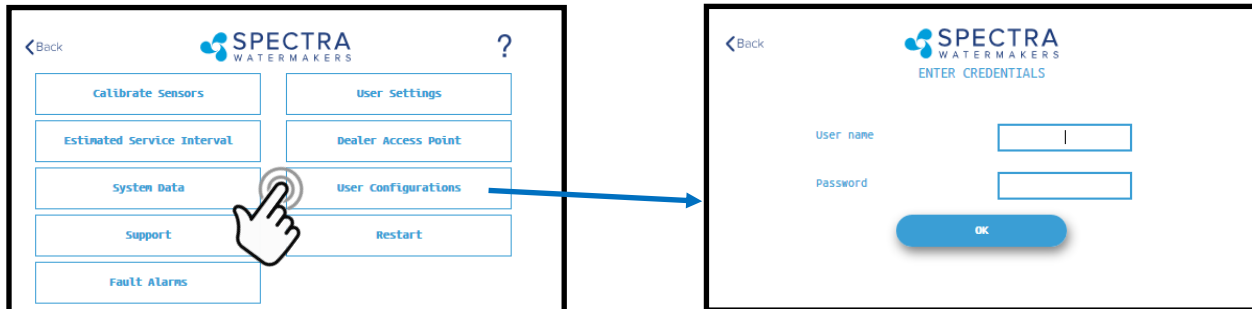

Default Login: admin  
Default Password: admin

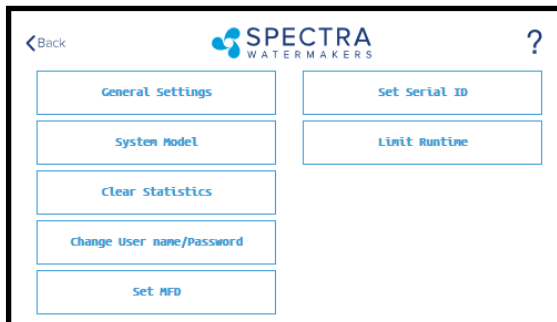

**System Model:** Configures the Spectra Connect for a different system model from a preset list of options.

**Clear Statistics:** Resets all of the Estimated Maintenance Intervals back to 100%. This feature should only be used on a brand new system.

**Change Username/password:** Changes the default username and password. If you forget your changed username and password, a Factory Reset will revert back to the default username and password.

**Set MFD:** Changes the Manufactured Date on the system. This should only be adjusted if a control board is being replaced on an older system.

**Set Serial ID:** Changes the Serial Number recorded in the Spectra Connect. This should only be adjusted if a control board is being replaced on an older system.

**Limit Runtime:** Limits the maximum run time for the system before shutting down and fresh water flushing. Disabling this setting allows the watermaker to be operated 24/7.

# Dealer Access Point - Settings Cont.

## Dealer Access Settings

It is highly recommended that users consult with a factory trained technician before altering any settings behind the 'Dealer Access Point'. **Changing this settings without understanding the full effect of each change can void the warranty of your system, and cause irreparable damage.**

If any settings are inadvertently changed, they can be reverted back to the defaults by using the 'Factory Reset' feature.

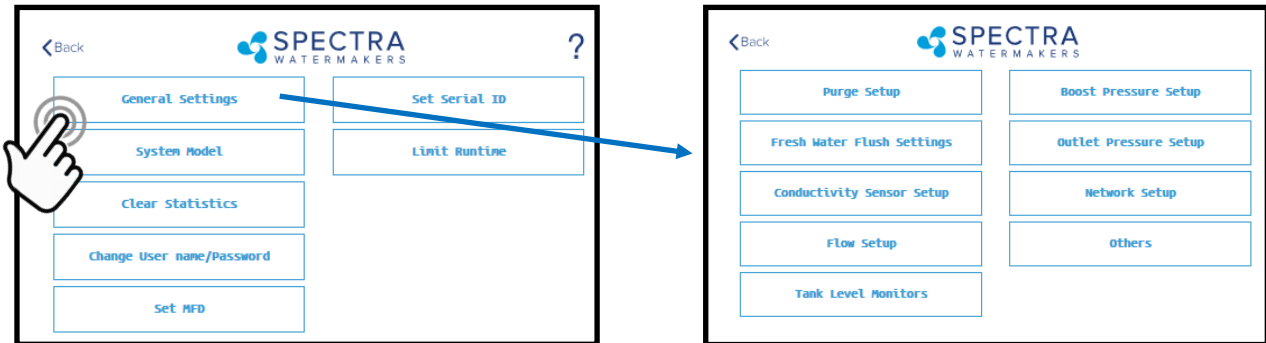

**Purge Setup:** Adjusts the time and maximum feed pressure allowed for the Purge Mode. **CAUTION: Permanent damage to the membrane can occur if this setting is adjusted. Consult the factory before making any adjustments.**

**Fresh Water Flush Settings:** Allows adjustment of the fresh water flush duration and the interval between flushes. If the Z-Ion is installed, the Flush Interval should be changed to 30 days.

**Conductivity Setup:** Allows for enabling or disabling conductivity sensors on the feed water and product water. Set the threshold for the diversion valve to divert water to the tanks.

**Flow Setup:** Allows the user to adjust the flow sensor settings, or disable a flow sensor circuit altogether. **DO NOT USE THIS SETTING TO CALIBRATE THE PRODUCT FLOW.** Follow instructions on calibrating the flow sensor in this manual.

**Tank Level Monitors:** Enable and disable the Tank Level Sensors, which read the % remaining in the tank, and the tank level switches, which allow the system to turn on/off automatically.

**Boost Pressure Setup:** Enable alternate Boost Pressure sensors, change the Low Vacuum Limit, or Boost Pressure Setpoint. **CAUTION: Permanent damage to the pump can occur if this setting is adjusted. Consult the factory before making any adjustments.**

**Low Vacuum Limit:** The minimum boost pressure required at the inlet to the pump. This setting prevents the pump from getting damaged by running under high vacuum. Adjusting it to a lower number increases the risk that the pump will suffer damage during normal operation.

**Boost Pressure Setpoint:** During startup the controller turns on the boost pump and waits for the Boost Pressure to reach the Boost Pressure Setpoint. If the boost pressure fails to reach this setpoint, then the main pump won't turn on. Reducing the Boost Pressure Setpoint may cause the system to start, then immediately shut down due to low boost pressure.

**Outlet Pressure Setup:** Set High Pressure Limit, enable alternate high pressure sensors, select pressure sensor scaling. **CAUTION: Permanent damage to the pump can occur if this setting is adjusted. Consult the factory before making any adjustments.**

**Network Setup:** Enabling the Spectra Connect Wireless access turns on a Power Over Ethernet feature on the wired connection. **ENABLING THIS FEATURE CAN CAUSE SERIOUS DAMAGE TO YOUR SHIP'S NETWORK. DO NOT ENABLE THIS FEATURE WITHOUT CONSULTING A QUALIFIED TECHNICIAN OR THE FACTORY.**

# Dealer Access Point - Settings Cont.

## Dealer Access Settings

It is highly recommended that users consult with a factory trained technician before altering any settings behind the 'Dealer Access Point'. **Changing this settings without understanding the full effect of each change can void the warranty of your system, and cause irreparable damage.**

If any settings are inadvertently changed, they can be reverted back to the defaults by using the 'Factory Reset' feature.

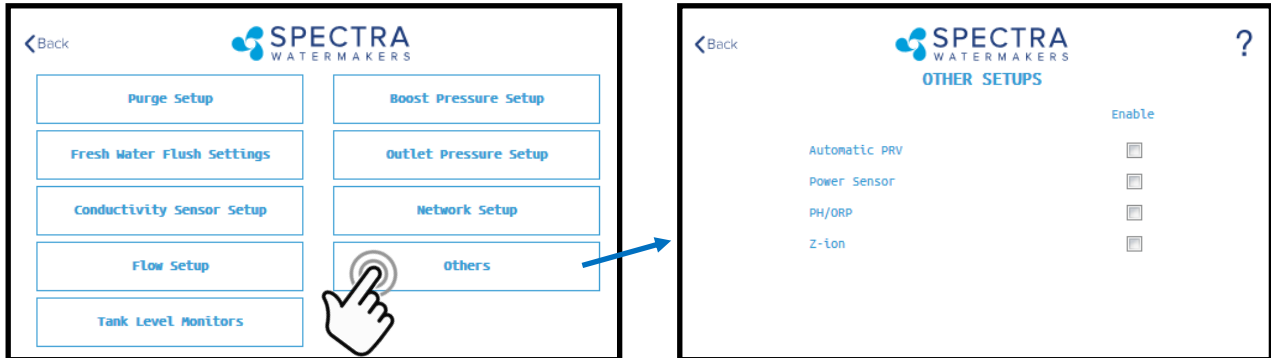

### Other Setups—Default is all disabled

**Automatic PRV:** Enables an optional Automatic Pressure Relief Valve, after it is installed. This setting should remain off unless you are certain that you have this feature installed on your system.

**Power Sensor:** Enables or disables an optional power sensor, after it is installed.

**PH/ORP:** Enables an optional pH or ORP meter, after it is installed.

**Z-Ion:** Enables or Disables the optional Z-Ion system, after it is installed. If the Z-Ion is enabled, you should also adjust the Flush Interval to 30 days.

## Tank Level Monitors



**Tank Setup** - Enable/disable tank sensors.

**Enable Tank Switch High** - Enable/disable tank high switch high. If this is disabled Auto Fill and Fill Tank run modes will not be available.

**Enable Tank Switch Low** - Enable/disable tank high switch low. If this is disabled Auto Fill mode will not be available. Both High and Low tank switches must be enabled for Auto Fill mode.

**Enable Tank Level 1** - Enable/disable tank level sensor 1. If this is disabled there will be no tank level reading and tank level gauge will read "!".

**Enable Tank Level 2** - Enable/disable tank level sensor 2..

# Handling Spectra Connect Alarms or Faults

Faults are (potentially hazardous) conditions that might occur during running of your watermaker. The control board has the ability to monitor these faults in real time and take necessary actions to prevent damaging your equipment.

## HIGH PRESSURE FAULT

High pressure fault is triggered if

Outlet pressure (Feed/Membrane pressure) > Pressure Limit

If a high pressure fault is triggered, the system goes to low production mode if it is running in high production mode, or stops the operation if it is already running in low production mode. Then the system will begin the Auto Store mode.

### Resolutions

Check for kinked or blocked hoses.

Confirm “#3 Sensor PSI High limit” and “#3 Sensor PSI Offset” options on Outlet Settings.

Clean membrane.

## SYSTEM STALL FAULT

System stall fault is triggered if

There is no product flow for 1 minute continuously.

If system stall fault is triggered, machine will stop the current run cycle and will prompt to restart. If restarted it will retry the previous running mode. If the stall condition persists even after restart, the system will begin the Auto Store mode.

### Resolutions

Confirm product water at membrane endcap.

Check intake line for restrictions, blockages or air leaks.

Close Pressure Relief Valve on Pump.

Confirm controller settings correct.

## SERVICE PREFILTER FAULT

The Service Prefilter fault is triggered if

Inlet Pressure(boost pressure) < Low Vacuum Limit

If the Service Prefilter fault triggers, the system goes to low production mode if it is running in high production mode or stops the operation if it is already running in low production mode. Then the system will begin the Auto Store mode.

### Resolutions

Change prefilters and the sea strainer screen.

Confirm adequate boost pressure in inlet pressure settings.

Check for obstructions in intake line.

Check sensor for proper operation

## POOR QUALITY FAULT

The High Salinity fault triggers if

The Salinity of the product water is above the threshold (measured salinity > Salinity 1 threshold) for more than 8 minutes.

If the High Salinity fault is triggered, the machine will stop the current run cycle and will prompt to restart. If restarted it will retry the previous running mode. If the High Salinity fault condition persists even after restart, the system will begin the Auto Store mode.

### Resolutions

Check pump operation - Clark Pump (pressure relief valve closed), Feed Pump (moving water).

Confirm product water quality.

Membrane damage - clean or replace.

Salinity probe out of calibration.

Clean or replace salinity probe.

**Spectra Land Based System Troubleshooting**

Fault	Probable Cause	Remedy
<b>Pump runs constantly, will not turn off</b>	Toggle switch on control box to RUN MAN or SERVICE	Turn switch on control box to RUN AUTO
	Speed Control damaged	Replace Speed Control
<b>Pearson Pump knocking</b>	Low or high Boost pressure	Adjust Boost pressure
	Intake blocked	Re-prime system (restart)
	Air in system	Check fresh water flush module for leaks
<b>No lights or display, system does not operate</b>	Display has gone to sleep	Touch the screen to wake it up
	Remote display not connected	Check display cable connections at back of display and at control box
	No power to control box	Check and reset main DC supply breaker
		Check for voltage control box, check 20A fuse on control board.
		Try manual switch on control box: If pump runs, then control or display may be defective
<b>Display activates, but pump will not run</b>	Loose or broken pump wire connection	Check wiring at terminal block inside control box
	Tanks are full (if equipped with tank switch)	Check tanks– system cannot be started if tanks are full when in Auto Fill mode.
		Improve cooling
<b>System runs, no product water delivered to water tanks, Product volume gauge good, Diversion valve shows activated on display</b>	Diversion valve inoperative or wiring fault.	Check wiring at diversion valve and inside control box
	Disconnected or broken product tubing	Check product tubing
	Diversion valve plunger stuck	Exercise diversion valve by pressing the manual button top, retest.
		Replace diversion valve.
<b>System runs, no product water delivered to water tanks, Product volume gauge good, Diversion valve shows deactivated on display</b>	Poor product water quality diversion valve open	Check for low feed pressure
	Salinity probe out of calibration or defective, bad cable	Check for leaks at high pressure hoses
	Chlorine damage to membranes	Test product water with hand-held tester– if over 500 PPM for 1 hour, see ‘Poor Product Quality’
	Pressure relief valve partially open	Close pressure relief valve
<b>“System Stalled” alarm is caused by the Rotoflow not reading properly, or no product flow</b>	Pressure relief valve open	Close pressure relief valve
	Intake thru-hull closed	Check thru-hull
	Airlocked system	Purge air
	No signal from Rotoflow meter	Check wiring, confirm Rotoflow is spinning, clean or replace Rotoflow meter



**Spectra Land Based System Troubleshooting Cont.**

<b>“High Pressure”</b>	Blocked brine discharge or product line	Check brine discharge and Product line
	Fouled membrane	Clean membrane
<b>“Service Prefilter”</b>	Clogged filters	Install new filters
	Loose or defective pressure sensor wires	Check sensor wiring
		If the error persists, follow Prefilter Calibration instructions.
<b>“Salinity High”</b>	High product water salinity	Confirm pressure relief valve is closed
	Chlorine damage to membranes	Check for low feed (membrane) pressure
	Defective salinity probe or cable	Check for leaks at high pressure hoses
	Bad or defective connector	Remove and clean probe contacts. Check calibration
		Check cable connections
		Clean membrane (See Tech Bulletin)
<b>“Can’t Connect to Watermaker from Web Browser”</b>	Device (phone/tablet/computer) not connected to same network	Check the wireless network on your mobile device or computer
	Router/Switch turned off	If using a wired connection, confirm you are connected to the same network.
	Watermaker turned off	Make sure Router/switch has power.
	Connecting to wrong web address	Restart Router/Switch
		Make sure watermaker is powered on
		Confirm Device IP address matches address typed into browser



# Operation and Repair Bulletins

The following documents are sections of our complete service bulletin set available on our website [Spectrawatermakers.com](http://Spectrawatermakers.com). Technical Support, - Service Bulletins.

## MB-2 MEMBRANE CARE

Membrane life is affected by a large number of factors and is somewhat unpredictable, however five or six years of use is typical. The biggest killers of membranes are lack of use, chlorine damage, and improper storage.

Don't let membranes sit around with sea water or stale fresh water in them. Biological growth will occur in the membrane. Here at the factory we frequently get back membranes for inspection that reek of hydrogen sulfide (rotten eggs). This odor is produced by anaerobic bacteria that live in an unused membrane, feeding on whatever animal or vegetable matter is trapped in it from the plankton that gets through the system. Membranes badly fouled in this way can seldom be saved. These bacteria are always present but are inhibited by the oxygen in sea water while the unit is in frequent use. If you won't be frequently using your membrane you can prevent biological growth by Fresh Water Flushes or by Pickling your membrane. Keeping the prefilters clean is also important in preventing bio-fouling. If your prefilters are allowed to become a breeding ground for bacteria (get smelly), the contamination will spread throughout the system. When we cut open a failed membrane we also find mildew, another form of bio fouling, probably due to long term storage with no biocide or stale biocide.

After many hours of water making mineral deposits will form and must be dissolved away with an acid cleaner. Alkaline cleaners are used for bio-fouling.

Chlorine destroys a membrane in minutes. It attacks the material that the membrane is made from. Always use product water or water filtered through a charcoal filter for flushing and chemical treatments.

Oil clogs the membrane. We have brought back oil fouled membranes with dish soap (See MB-5 Cleaning with Detergent.)

For storage we recommend using SC-1 or propylene glycol potable water system antifreeze if available. Propylene glycol can safely be left in the system for one year and will keep things from freezing in cold conditions. It is hard to find in warm climates, and takes up a lot of room on a small boat, so our SC-1 is best for tropical cruising.

Even if given good care a membrane will eventually start to slowly fade away. The feed pressure may rise and/or the ppm go up.

## Poor Product Water Quality

With any product water quality issue, you must ensure accurate calibration if you are using a salinity meter. For general quality evaluation, your taste is always good enough.

Membranes are not an exact science and two identical systems can have different product quality. World health standards deem water of up to 1000 PPM of total dissolved solids acceptable for drinking. We consider any thing below 750 PPM acceptable, and anything below 500 PPM excellent. Factors that could affect water quality are addressed below.

LOW SYSTEM FLOW OR PRESSURE will equate to lower product quality (higher PPM).

DAMAGE TO THE MEMBRANE by chlorine contamination. Flushing the system with chlorinated water will irreparably damage the membrane. Charcoal filters are used to absorb any chlorine which might be present in flush water. They must be of proper specification to be suitable. There is no test for chlorine damage except the process of elimination of other causes.

DIRTY OR SCALED membranes. A dirty (foreign material), scaled (mineral deposits), or contaminated (bacterial growth) membrane can result in poor water quality and abnormal operating pressures. If operating pressures are above normal, then cleaning is indicated. If the system pressures are within normal operating range, cleaning may have little result. Low water quality after storage with propylene glycol can usually be remedied by flushing with the pressure relief valve for several hours or if that is not effective a SC-2 cleaning.

MECHANICAL LEAKAGE within the membrane pressure vessel. This is an unlikely but possible cause of poor water quality. A pinched or damaged O-ring within the pressure vessel, a scratch on the product tube on the membrane, a scratch within one of the end caps, or a seal fouled by contamination could allow sea water into the product water.

## **MB-5 MEMBRANE CLEANING WITH DETERGENT**

If the membrane has been fouled with oil it may be possible to save it by cleaning with dish soap such as Joy. Do not use anything that contains bleach. You will need a lot of chlorine free fresh water so either use unchlorinated product water or get a carbon filter that will handle 6 gpm (23 lpm)

Use the “Membrane Cleaning Procedure”

Fill a bucket with fresh water and mix in a couple squirts of the detergent. Run the system unpressurized (with pressure relief valve open) with the watermaker drawing water from the bucket and discharging to an acceptable drain site. When about half the water is gone from the bucket stop the unit and let the membrane soak for a few minutes. Restart and pump the remaining solution overboard. Repeat until the discharge appears clean.

After most of the oil is cleaned out you can put the brine discharge into the bucket and run the system with the soapy water circulating as you would for the other cleaning chemicals. Run the Fresh Water Flush cycle to clean membrane, then flush for twenty minutes using feed water. Pressurize and test.

## **BAD SMELLING PRODUCT WATER**

The reverse osmosis membrane is permeable by many gases including hydrogen sulfide, the gas that causes rotten egg smell. If there are bad odors in the feed water they will go through the membrane and the product water will be affected. Usually the source of the odor is from the decay of plankton trapped in the sea strainer and prefilters. These tiny oxygen loving creatures soon suffocate and die inside the prefilter housings when the unit is shut down and begin to decay. Once this decay starts the only solution is to rinse the prefilter and let it dry completely (to kill the bacteria) or just replace it with a new filter. If the system is making smelly water, it will likely be the prefilters that are the source of the problem. In cold climates this process of decay can take weeks, but in very warm waters this can happen overnight. These bacteria can spread throughout the watermaker, and begin to grow on the membrane, causing poor water quality and high feed pressures.

Flushing the system with fresh water after every use greatly slows this process, allowing the automated spectra units to operate with less frequent prefilter changes, but units operated for only an hour or so a day will probably need to have the filters changed due to odor before they are dirty enough to restrict water flow. After shutting down the unit remove the used prefilters and install a clean set. Leave the housings full of air until the next use.

If the rotten egg smell does not go away after operating the watermaker for 6 or 8 hours it may be time to clean the membrane with SC-2. Typically the smell will go away with use, but if it persists cleaning may be indicated.

More on this subject is available on our website at [www.spectrawatermakers.com](http://www.spectrawatermakers.com).

# LB-1800-2800-4000 Electrical Diagram

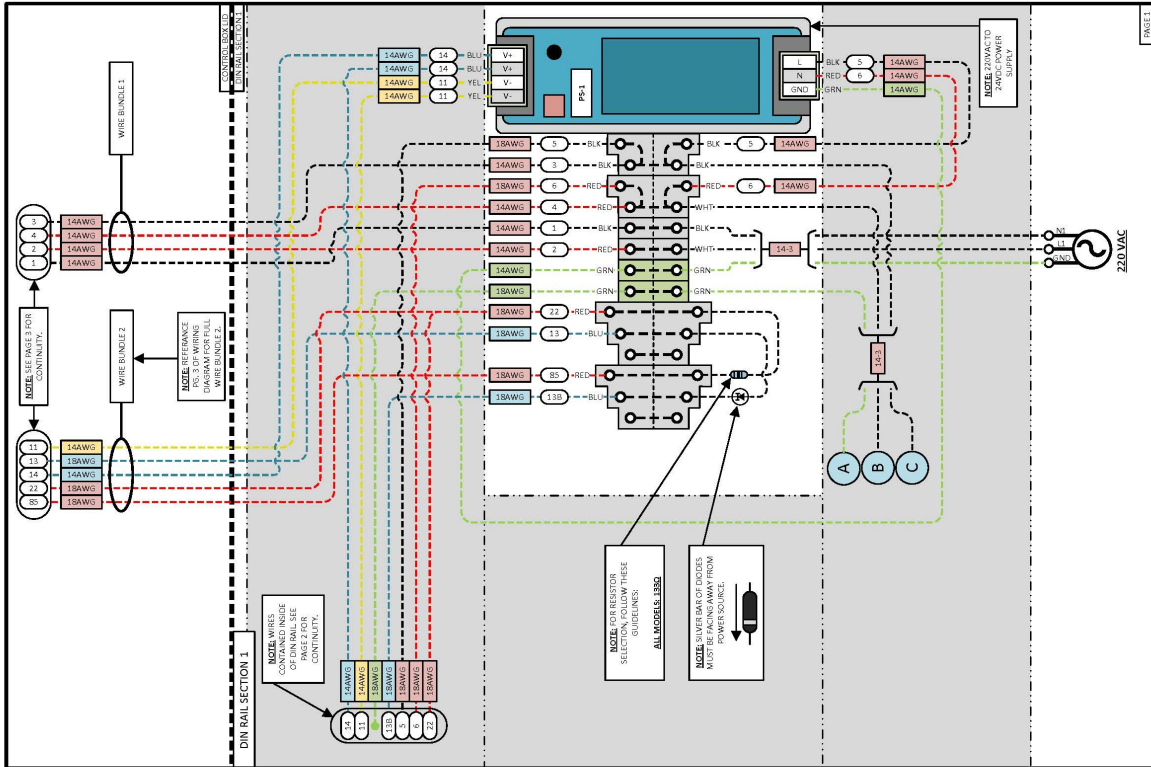

List of Symbols KEY	
	WIRE COLOR LABEL - INDICATES A BLACK WIRE
	WIRE COLOR LABEL - INDICATES A RED WIRE
	WIRE COLOR LABEL - INDICATES A GREEN WIRE
	WIRE COLOR LABEL - INDICATES A YELLOW WIRE
	WIRE COLOR LABEL - INDICATES AN ORANGE WIRE
	WIRE COLOR LABEL - INDICATES A BLUE WIRE
	WIRE GAUGE LABEL - INDICATES GAUGE FOR A SINGLE WIRE
	CAT5 ETHERNET CONNECTION PORT
	USB CONNECTION PORT
	LCD-SP CONNECTION PORT
	FUSE - NECESSARY USING INFORMATION CALLED OUT ON WIRING DIAGRAM
	CABLING - JST AND CAT5 PRE-FABRICATED CABLES
	WIRING - SINGLE WIRE BLACK OR WHITE - TYPICAL COMMON COLOR
	WIRING - SINGLE WIRE RED - TYPICAL ENERGIZED COLOR
	WIRING - SINGLE WIRE YELLOW - TYPICAL NEUTRAL COLOR
	WIRING - SINGLE WIRE GREEN - TYPICAL GROUNDING COLOR
	WIRING - SINGLE WIRE ORANGE - TYPICAL POWER SIGNALING COLOR
	WIRING - SINGLE WIRE BLUE - TYPICAL POWER SIGNALING COLOR
	SECTION DIVIDER - CONTROL BOX - NOT A PHYSICAL ELEMENT
	WIRING NODE - WIRE BUTT SPICE CONNECTION
	DIODE - ELECTRICAL DIODE - CURRENT FLOW IN DIRECTION OF ARROW
	EXTERNAL POWER SOURCE - POWER EXTERNAL TO UNIT, PROVIDED TO UNIT - 220VAC
	NOTATION - NOTE CALLS OUT INDICATES THAT APPLIES TO MULTIPLE AREAS OF THE DIAGRAM - SMALL NUMBER IN CIRCLE
	NOTATION - WIRE CONTINUITY SYMBOL INDICATES CONTINUITY BETWEEN MATCHING ALPHABETIC SYMBOLS - LARGE ALPHABETIC CIRCLE
	JUMPER - INDICATES PLACEMENT AND TERMINATION LOCATION FOR JUMPER - 2 OR 4 PIN - 2 PIN SHOWN
	WIRING - PASS THROUGH CONNECTOR - BU45/45/12

**Detail View 1: Control Box Section Identification**

**CONTROL BOX LID**

**DIN RAIL SECTION 1**

**DIN RAIL SECTION 2**

**WIRE BUNDLE 1**

**WIRE BUNDLE 2**

**Revision History: LB-1,800/2,800/4,000C-220V**

Rev/Iss	Date	Description
A	02/17/2023	REVISED ELECTRICAL WIRING DIAGRAM FOR REVISED CONTROL BOX LID PART NUMBER 220V

**Control System:**

- V5.0 Firmware
- 220V Input Voltage

**Applicable System Numbers:**

- LB-1,800C-220V
- LB-2,800C-220V
- LB-4,000C-220V

**Land Based: LB-1,800/2,800/4,000C-220V**

**Revision: A**

**Rev Date: 02/17/2023**

**Print Date: 02/17/2023**

**Drawn by: LSS**

**Katadyn Desalination**

# LB-1800-2800-4000 Electrical Diagram Cont.

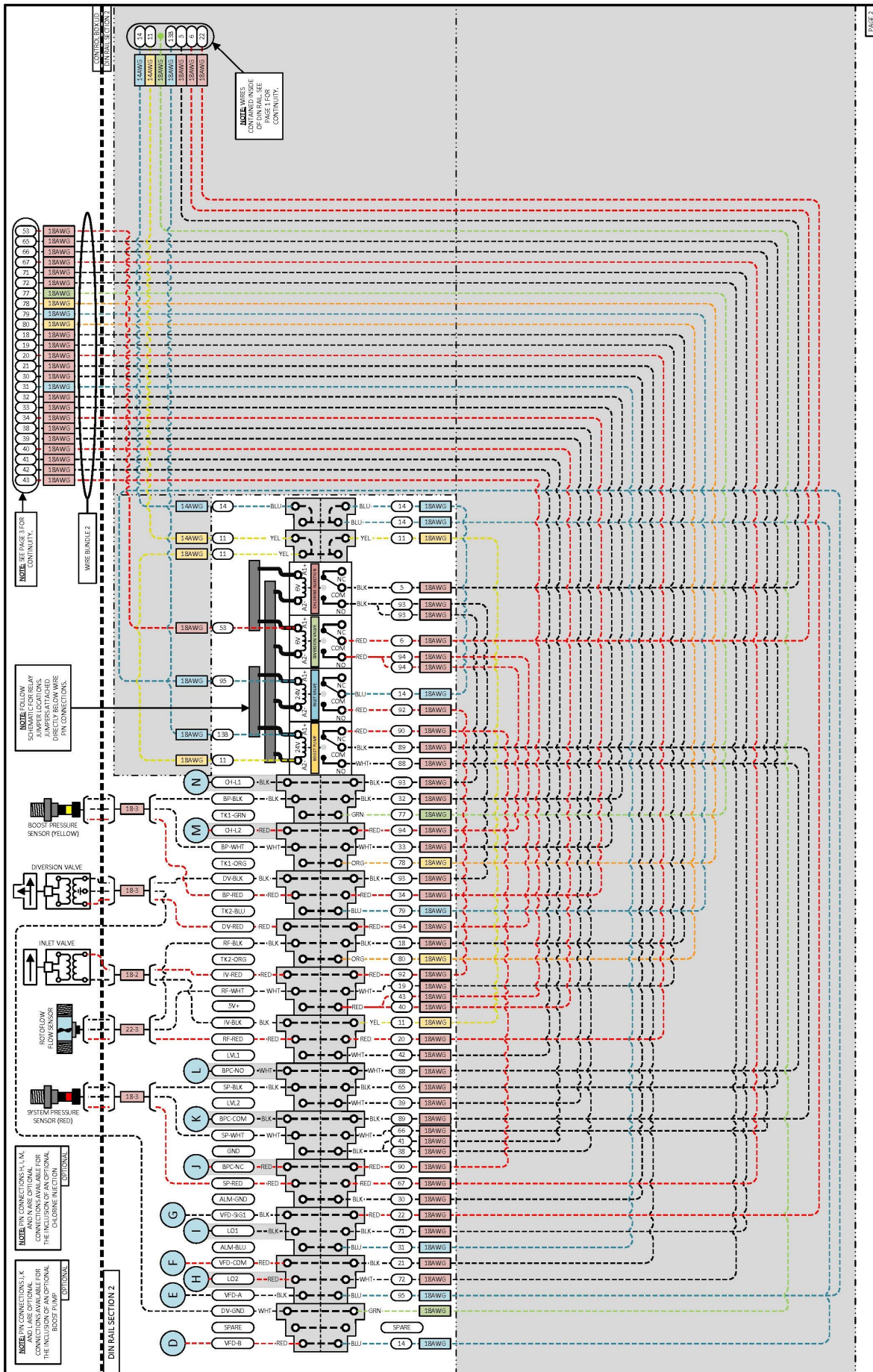



# LB-1800-2800-4000 Electrical Diagram Cont.

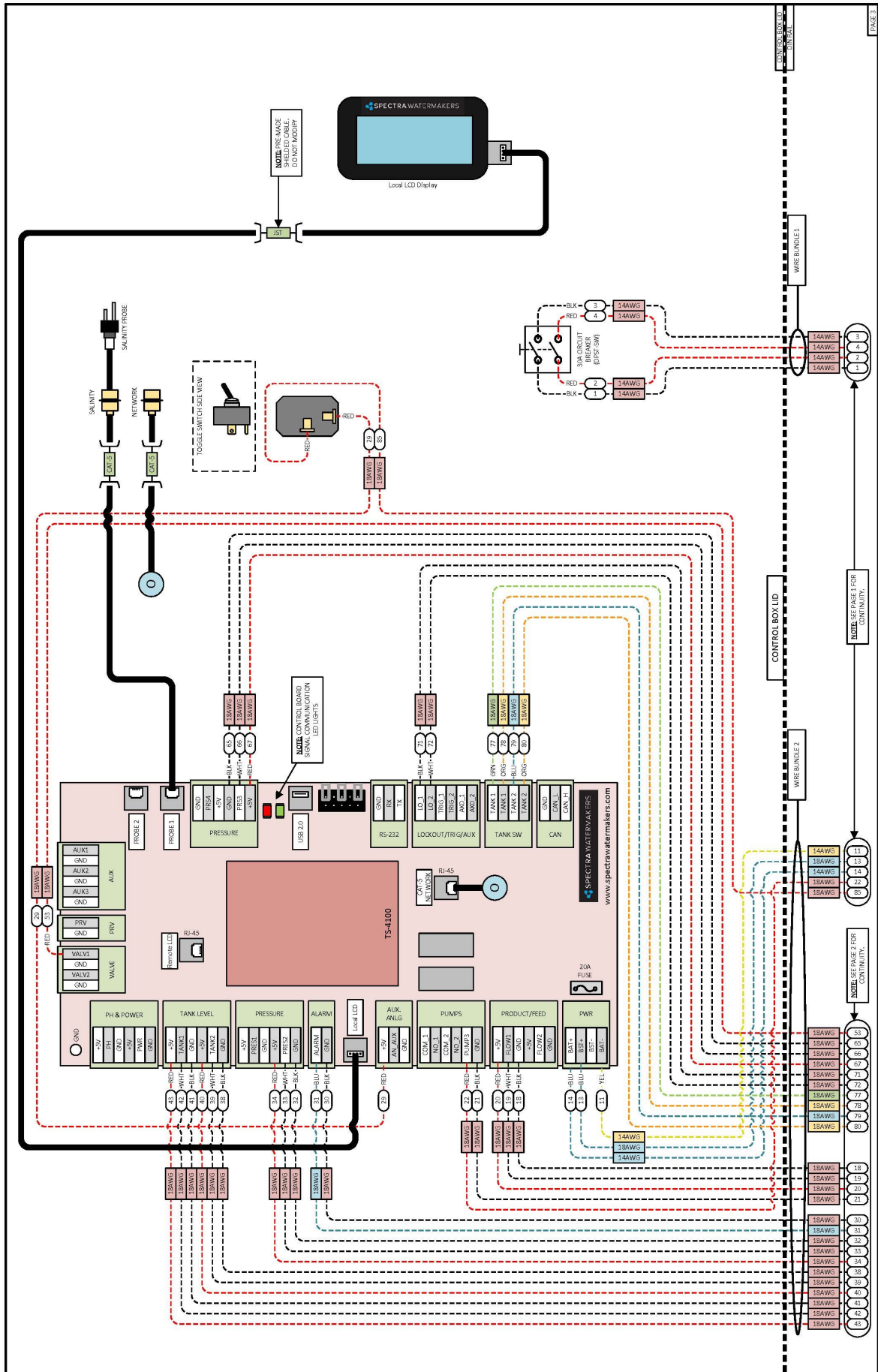

# LB-1800-2800-4000 Electrical Diagram Cont.

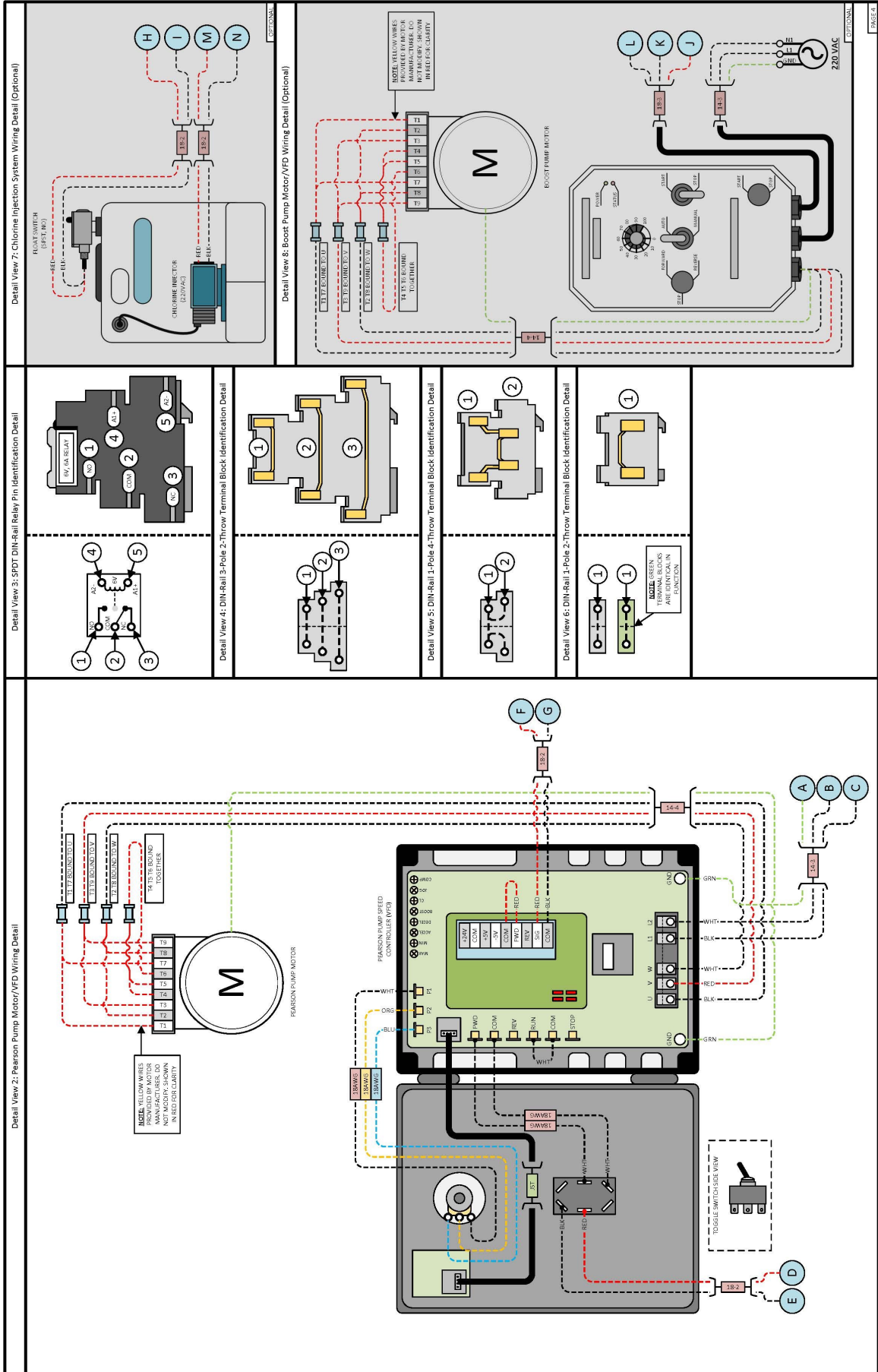

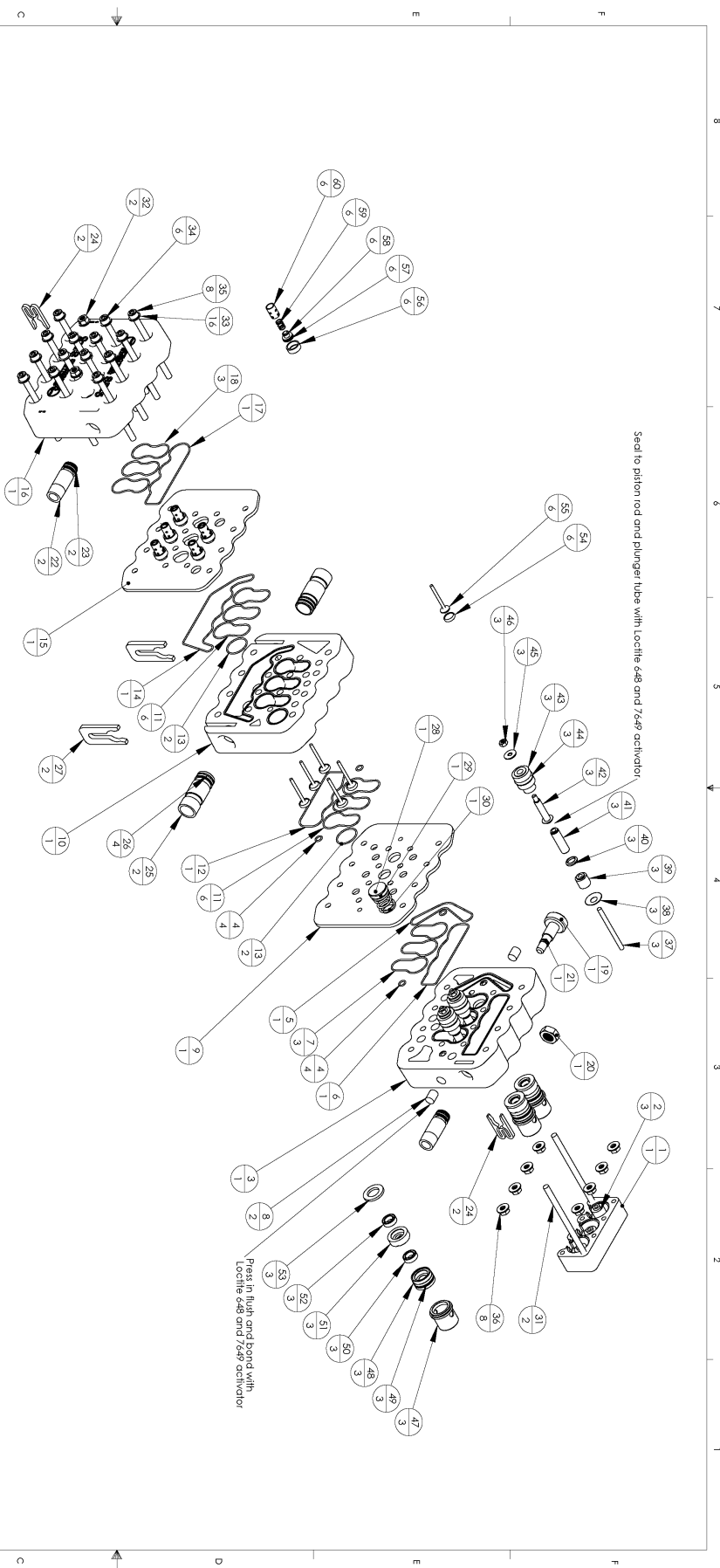

ITEM NO.	Part Number	QTY.	Description	ITEM NO.	Part Number	QTY.	Description	ITEM NO.	Part Number	QTY.	Description
1	PP-5MCC-CAC	1	PP5M CRANK CASE DRIVE END CAT	21	SO-PP20-RV	1	PP5M O-RING RELIEF VALVE 012 N70	42	PP-5MCP-PT-RQD2	3	PP5MCP PISTON ROD 20% REV B
2	INO-PPACT-FI	3	CAT COP CROSSHEAD	22	PP-5M-FI-12LIC	2	PP5M FITTING TUBE 1.2 IN I.D. 37DEG	43	PP-5MCP-PT-P12	3	PP5MCP 5CP PISTON 20% REV A
3	PP-5MCP-LV1	1	PP 5MCP LAYER 1	23	SO-PP5-DP	2	PP5M O-RING 1.2 IN I.D. 118R	44	SO-PP5-FD	3	PP5M O-RING PISTON DAMPER 313 N70
4	SO-PP50-FLUSH	4	PP5M O-RING FLUSH 011 NBR SHORE 70A	24	PP-5M-FI-12HPC	2	PP5M FITTING O-RING 1.2 IN I.D. NBR	45	PP-5MCP-HWR-4M4W	3	M8 WASHER 316 SS
5	PP-5MCP-LV2	1	PP5M O-RING LT RELIECT 043 N70	25	PP-5M-LP-F134NU	2	PP5M LP FITTING 3/4" NPT LH/WV	46	PP-5MCP-HWR-4M8W	3	M8 NUTLOCK INSERT LOCK NUT 316 SS
6	SO-PP5M-LV1R	1	PP5M O-RING LT CYLINDER 031 N70	26	PP-5M-LP-F134NU	2	PP5M LP FITTING O-RING 3.4IN. 020 N70	47	PP-5MCP-SEAL-L12	3	PP5MCP 5CP LP SEAL RETAINER REV A
7	SO-PP5M-CPLV4	3	PP5M O-RING LT CYLINDER 031 N70	27	PP-5M-FI-34LIC	2	PP5M FITTING CLIP 3.4IN LP REV A	48	SO-PP5M-20LPS	3	PP5M LP SEAL 20%
8	PP-5M-LV1P	1	PP 5MCP LAYER 2	28	PP-5MCP-PT	1	PP DAMPER PISTON	49	SO-PP5M-20LPS	3	PP5M LP SEAL 20%
9	PP-5MCP-LV2	1	PP 5MCP LAYER 3	29	SO-PP5-DP	1	PP5M O-RING PISTON DAMPER 313 N70	50	PP-5MCP-PT	3	PP5 SEAL CASE 023 N70
10	PP-5MCP-LV3	6	PP5M O-RING LT CYLINDER 031 N70	30	PP-5M-SP	1	PP5M DAMPER SPRING	51	PP-5MCP-SEAL-H2	3	PP5MCP 5CP HP SEAL CASE 20% REV A
11	SO-PP5-CPLV4	1	PP5M O-RING LT CYLINDER 031 N70	31	PP-5M-SP	2	PP 5MCP M8 X 1.50 STUD REV A	52	PP-5MCP-SEAL-H2	3	PP5 HP SEAL 20%
12	SO-PP5M-LV3V1T	1	PP5M O-RING LT WASHER 042	32	PP-5M-SP	2	M8 HEX NUT 18-8	53	SO-PP5M-20LPS	3	PP5MCP 5CP HP SEAL WASHER 20%-30%
13	SO-PP5M-L3BP	2	PP5M O-RING LT WASHER 024 N70	33	PP-5M-SP	16	M8 WASHER 18-8	54	PP-5M-LV1V	3	PP5 PUMP VALVE SHOE
14	SO-PP20-LV1HP	1	PP5M O-RING LT DAMPER 024 N70	34	PP-5M-SP	6	M8 X 1.40 SGT COP SCREW 18-8	55	PP-5M-LV1V	3	PP5 PUMP VALVE
15	PP-5MCP-LV4	1	PP 5MCP LAYER 4	35	PP-5M-SP	8	M8 X 20MM SOCKET COP SCREW 18-8	56	PP-5M-LV1V	6	PP5 VALVE SLIDE STEPPED
16	PP-5MCP-LV5	1	PP 5MCP LAYER 5	36	PP-5M-SP	8	M8 X 1.25 FLANGE NUT 18-8 SS	57	SO-PP5-LV1P	6	PP5 VALVE PLUG 019 N70
17	SO-PP5M-LV1R	1	PP5M O-RING LT CYL 043 N70	37	PP-5MCP-PT	3	PP5MCP 5CP PLUNGER STUD REV B	58	PP-5-LV1V1P	6	PP5 VALVE PLUG 0.508 GROOVE
18	SO-PP5M-L3CVL	3	PP5M O-RING LT CYLINDER 031 N70	38	SO-PP5MCP-2HW	3	CAT COP KEYSIDE WASHER 4897 REV A	59	PP-5-LV1V1P	6	PP5 VALVE SPRING
19	PP-5M-RS	1	PP5M RELIEF SCREW REV C	39	SO-PP5MCP-2HW	3	PP5MCP 5CP PLUNGER TUBE 20% REV A	60	PP-5-LV1V1G	6	PP5 VALVE SPRING
20	PP-5M-RS	1	PP5M RELIEF NUT S4	41	PP-5MCP-PT	3	PP5MCP 5CP PLUNGER TUBE 20% REV A	61		6	

Remove all burrs and sharp edges, max radius 0.010"

Material											
Surface Finish	Inches	B	11/0316	Layers 1, 3 & 5 use moldings from modified tool							
Tolerances		A		1st issue SPSM Layer 1 Rev F SPSM Machined Layer 3 Rev A SPSM Layer 5 Rev E Layers 1 & 5 use moldings from unmodified tool							
SCALE 1:10	Do not scale	Isometric Projection	Rev	Date	Purpose & Changes						

**SP5M 5CP Assembly 20% Rev D Exploded**

Contact: Spectra Watermakers  
 Phone: (415) 526-2790  
 E-mail: customer.service@spectrawatermakers.com

Rev D SH 1 of 1  
 Dwg No. 2

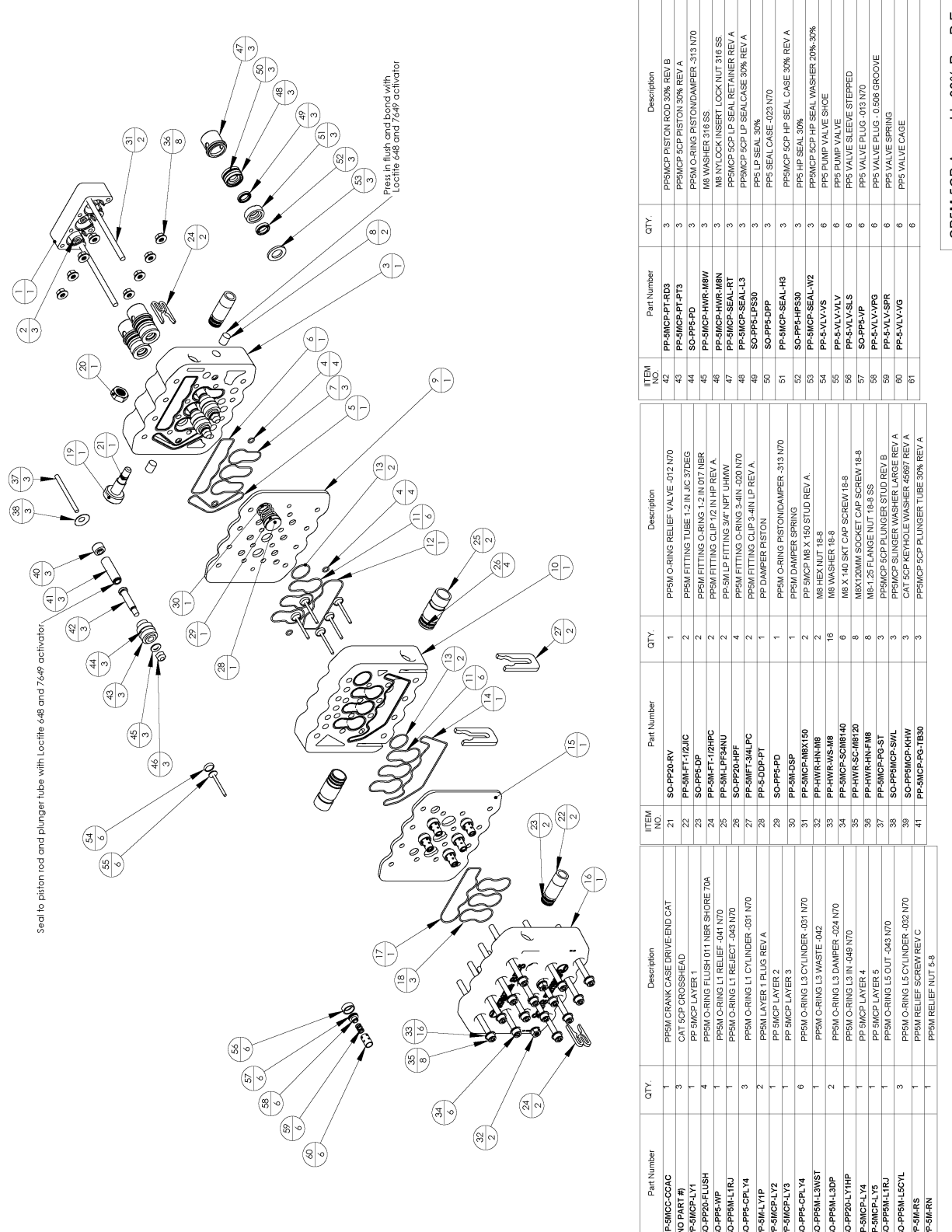

Seal to piston rod and plunger tube with Loctite 648 and 7649 activator.

Press in flugh and bond with Loctite 648 and 7649 activator

ITEM NO.	Part Number	Description	QTY.	ITEM NO.	Part Number	Description	QTY.	ITEM NO.	Part Number	Description	QTY.
1	PP-5MCC-CGAC	PP5M CRANK CASE DRIVE END CAT	1	21	SO-PP20-RV	PP5M O-RING RELIEF VALVE -012 N70	1	42	PP-5MCP-PT-FR03	PP5MCP PISTON ROD 30% REV B	3
2	(NO PART #)	CAT 5CP CROSSFIELD	3	22	PP-5MFT-12JIC	PP5M FITTING TUBE 1.2 IN JIC 37DEG	2	43	PP-5MCP-PT-F13	PP5MCP 5CP PISTON 30% REV A	3
3	PP-5MCP-LY1	PP 5MCP LAYER 1	1	23	SO-PP5-DP	PP5M FITTING O-RING 1.2 IN 017 NBR	2	44	SO-PP5-PD	PP5M O-RING PISTON/DAMPER -313 N70	3
4	SO-PP20-FLUSH	PP5M O-RING FLUSH 011 NBR SHORE 70A	4	24	PP-5M-FT-12HPC	PP5M FITTING CLIP 1/2 IN HP REV A	2	45	PP-5MCP-HWR-MBW	M8 WASHER 316 SS	3
5	SO-PP5-WIP	PP5M O-RING L1 RELIEF -041 N70	1	25	PP-5M-LP-PS4HU	PP-5M LP FITTING 3/4" NPT UHMW	2	46	PP-5MCP-HWR-MBW	M8 NY LOCK INSERT LOCK NUT 316 SS	3
6	SO-PP5M-LTRJ	PP5M O-RING L1 RELIEF -043 N70	1	26	SO-PP20-HPF	PP5M FITTING O-RING 3.4 IN -020 N70	4	47	PP-5MCP-SEAL-RT	PP5MCP 5CP LP SEAL RETAINER REV A	3
7	SO-PP5-CRLV4	PP5M O-RING L1 CYLINDER -031 N70	3	27	PP-5MFT-3M-LPC	PP5M FITTING CLIP 3.4 IN LP REV A	2	48	PP-5MCP-SEAL-L3	PP5MCP 5CP LP SEAL CASE 30% REV A	3
8	PP-5M-LY1P	PP5M LAYER 1 PLUG REV A	2	28	PP-5DDP-PT	PP DAMPER PISTON	1	49	SO-PP-LP-SS0	PP5M LP SEAL 50%	3
9	PP-5MCP-LY2	PP 5MCP LAYER 2	1	29	SO-PP5-PD	PP5M O-RING PISTON/DAMPER -313 N70	1	50	PP-5MCP-SEAL-H3	PP5MCP 5CP HP SEAL CASE 30% REV A	3
10	PP-5MCP-LY3	PP 5MCP LAYER 3	1	30	PP-5M-DSP	PP5M DAMPER SPRING	1	51	PP-5MCP-SEAL-W2	PP5M HP SEAL 30%	3
11	SO-PP5M-L3WST	PP5M O-RING L3 CYLINDER -031 N70	6	31	PP-5MCP-M8X150	PP 5MCP M8 X 150 STUD REV A	2	52	PP-5MCP-SEAL-W2	PP5M HP SEAL 30%	3
12	SO-PP5M-L3WST	PP5M O-RING L3 WASTE -042	1	32	PP-5MCP-M8X18	M8 HEX NUT 18-8	2	53	PP-5MCP-SEAL-W2	PP5M HP SEAL 30%	3
13	SO-PP5M-L3WST	PP5M O-RING L3 WASTE -042	2	33	PP-5MCP-M8X18	M8 WASHER 18-8	18	54	PP-5MCP-SEAL-W2	PP5M HP SEAL 30%	3
14	SO-PP5M-L3WST	PP5M O-RING L3 DAMPER -024 N70	2	34	PP-5MCP-M8X18	M8 X 1.40 SKT CAP SCREW 18-8	8	55	PP-5MCP-SEAL-W2	PP5M HP SEAL 30%	3
15	SO-PP5M-L3WST	PP5M O-RING L3 IN -048 N70	1	35	PP-5MCP-M8X20	M8 X 2.00MM SOCKET CAP SCREW 18-8	8	56	PP-5MCP-SEAL-W2	PP5M HP SEAL 30%	3
16	SO-PP5M-L3WST	PP5M O-RING L3 IN -048 N70	1	36	PP-5MCP-M8X20	M8 X 2.00MM SOCKET CAP SCREW 18-8	8	57	PP-5MCP-SEAL-W2	PP5M HP SEAL 30%	3
17	SO-PP5M-L3WST	PP5M O-RING L3 OUT -043 N70	1	37	PP-5MCP-M8X20	M8 X 2.00MM SOCKET CAP SCREW 18-8	8	58	PP-5MCP-SEAL-W2	PP5M HP SEAL 30%	3
18	SO-PP5M-L3WST	PP5M O-RING L3 OUT -043 N70	1	38	PP-5MCP-M8X20	M8 X 2.00MM SOCKET CAP SCREW 18-8	8	59	PP-5MCP-SEAL-W2	PP5M HP SEAL 30%	3
19	PP-5M-LRS	PP5M O-RING L5 CYLINDER -032 N70	3	39	PP-5MCP-M8X20	M8 X 2.00MM SOCKET CAP SCREW 18-8	8	60	PP-5MCP-SEAL-W2	PP5M HP SEAL 30%	3
20	PP-5M-LRN	PP5M RELIEF SCREW REV C	1	40	PP-5MCP-M8X20	M8 X 2.00MM SOCKET CAP SCREW 18-8	8	61	PP-5MCP-SEAL-W2	PP5M HP SEAL 30%	3
				41	PP-5MCP-PT-1850	PP5MCP 5CP PLUNGER TUBE 30% REV A	3				

ITEM NO.	Part Number	Description	QTY.
37	PP-5MCP-PT-F13	PP5MCP 5CP PISTON 30% REV A	3
38	PP-5MCP-PT-F13	PP5MCP 5CP PISTON 30% REV A	3
39	PP-5MCP-PT-F13	PP5MCP 5CP PISTON 30% REV A	3
40	PP-5MCP-PT-F13	PP5MCP 5CP PISTON 30% REV A	3
41	PP-5MCP-PT-F13	PP5MCP 5CP PISTON 30% REV A	3
42	PP-5MCP-PT-F13	PP5MCP 5CP PISTON 30% REV A	3
43	PP-5MCP-PT-F13	PP5MCP 5CP PISTON 30% REV A	3
44	PP-5MCP-PT-F13	PP5MCP 5CP PISTON 30% REV A	3
45	PP-5MCP-PT-F13	PP5MCP 5CP PISTON 30% REV A	3
46	PP-5MCP-PT-F13	PP5MCP 5CP PISTON 30% REV A	3
47	PP-5MCP-PT-F13	PP5MCP 5CP PISTON 30% REV A	3
48	PP-5MCP-PT-F13	PP5MCP 5CP PISTON 30% REV A	3
49	PP-5MCP-PT-F13	PP5MCP 5CP PISTON 30% REV A	3
50	PP-5MCP-PT-F13	PP5MCP 5CP PISTON 30% REV A	3
51	PP-5MCP-PT-F13	PP5MCP 5CP PISTON 30% REV A	3
52	PP-5MCP-PT-F13	PP5MCP 5CP PISTON 30% REV A	3
53	PP-5MCP-PT-F13	PP5MCP 5CP PISTON 30% REV A	3
54	PP-5MCP-PT-F13	PP5MCP 5CP PISTON 30% REV A	3
55	PP-5MCP-PT-F13	PP5MCP 5CP PISTON 30% REV A	3
56	PP-5MCP-PT-F13	PP5MCP 5CP PISTON 30% REV A	3
57	PP-5MCP-PT-F13	PP5MCP 5CP PISTON 30% REV A	3
58	PP-5MCP-PT-F13	PP5MCP 5CP PISTON 30% REV A	3
59	PP-5MCP-PT-F13	PP5MCP 5CP PISTON 30% REV A	3
60	PP-5MCP-PT-F13	PP5MCP 5CP PISTON 30% REV A	3
61	PP-5MCP-PT-F13	PP5MCP 5CP PISTON 30% REV A	3

Remove all burrs and sharp edges, max radius 0.010"  
 Material  
 Surface Finish  
 Dimensions  
 Tolerances  
 SCALE 1:10  
 Do not scale  
 Isometric Projection  
 Rev Date  
 Purpose & Changes  
 Layers 1, 3 & 5 use moldings from modified tool. Uses SP5 plunger tube with adaptor.  
 1st issue: SP5M Layer 1 Rev F, SP5M Layer 3 Rev A, SP5M Layer 5 Rev E. Layers 1 & 5 use moldings from unmodified tool.  
 Rev Date  
 Purpose & Changes

**SP5M 5CP Assembly 30% Rev D Exploded**  
 Contact: Spectra Watermakers  
 Phone: (415)-526-2780  
 E-mail: customerservice@spectrawatermakers.com  
 Dwg No: 2  
 Rev: D  
 Sht: 1 of 1

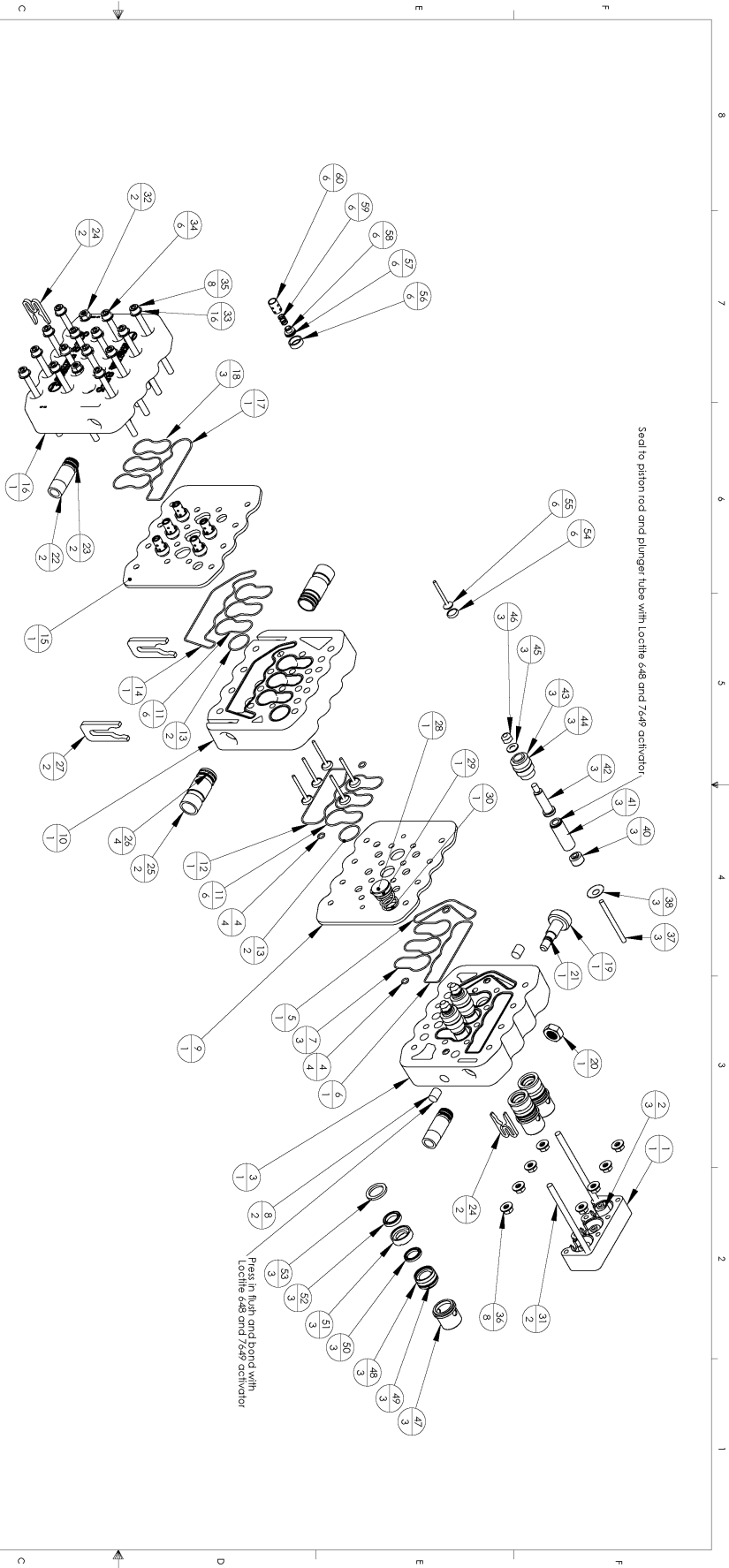

ITEM NO	Part Number	QTY.	Description	ITEM NO	Part Number	QTY.	Description	ITEM NO	Part Number	QTY.	Description
1	PP-5MCCCGAC	1	PP5M CRANK CASE DRIVE END CAT	21	SO-PP2BURY	1	PP5M O-RING RELIEF VALVE -012 N70	42	PP-5MCP-PT-RD5	3	PP5MCP PISTON ROD 50% REV B
2	INO PART #1	3	CAT SCP CROSSHEAD	22	PP-5MHT-1/2JUG	2	PP5M FITTING TUBE 1.2 IN JIC 37DEG	43	PP-5MCP-PT-F15	3	PP5MCP SCP PISTON 50% REV A
3	PP-5MCP-LY1	1	PP 5MCP LAYER 1	23	SO-PP5-DP	2	PP5M FITTING TUBES 1.2 IN JIC 37DEG	44	SO-PP5-DP	3	PP5M O-RING PISTON 50% REV A
4	SO-PP20-FLUSH	4	PP5M O-RING FLUSH 0111 NBR SHORE 70A	24	PP-5MHT-1/2HFC	2	PP5M FITTING CLIP 1/2 IN HP REV A	45	PP-5MCP-HWR-MBW	3	PP-5MCP-HWR-MBW
5	SO-PP5M-WIP	1	PP5M O-RING L1 RELIEF 041 N70	25	PP-5MCP-1/2SHU	2	PP5M LP FITTING 3/4" NPT UHMW	46	PP-5MCP-HWR-MBN	3	M8 WASHER 316 SS
6	SO-PP5M-L1M	1	PP5M O-RING L1 RELECT 045 N70	26	SO-PP20-9HT	4	PP5M FITTING RING 3.4IN 020 N70	47	PP-5MCP-SEAL-RT	3	M8 W/LOCK INSERT LOCK NUT 316 SS
7	SO-PP5M-CR1V4	3	PP5M O-RING L1 CYLINDER 031 N70	27	PP-5MHT-3/4LFC	2	PP5M FITTING CLIP 3.4IN LP REV A	48	PP-5MCP-SEAL-L5	3	PP5MCP 5CP LP SEAL CASE 50% REV A
8	PP-5M-LY1P	2	PP5M LAYER 1 PLUG REV A	28	PP-5-DOP-PT	1	PP DAMPER PISTON	49	SO-PP5-LP50	3	PP5 LP SEAL 50%
9	PP-5MCP-LY2 - 50%	1	PP 5MCP LAYER 2 - 50%	29	SO-PP5-DP	1	PP5M O-RING PISTON/DAMPER -313 N70	50	SO-PP5-DPP	3	PP5 SEAL CASE 023 N70
10	PP-5MCP-LY3	1	PP 5MCP LAYER 3	30	PP-5M-DSP	1	PP5M DAMPER SPRING	51	PP-5MCP-SEAL-H16	3	PP5MCP 5CP HP SEAL CASE 50% REV A
11	SO-PP5-CR1V4	6	PP5M O-RING L3 CYLINDER 031 N70	31	PP-5MCP-MBX150	2	PP 5MCP M8 X 150 STUD REV A	52	SO-PP5-PT-SSD	3	PP5 HP SEAL 50%
12	SO-PP5M-L1MST	1	PP5M O-RING L3 WASTE 042	32	PP-5MCP-MBX150	2	M8 HER NUT 18-8	53	PP-5MCP-SEAL-W15	3	PP5MCP 5CP HP SEAL WASHER 50%
13	SO-PP5M-L1MST	2	PP5M O-RING L3 WASTE 042	33	PP-5MCP-MBX150	2	M8 WASHER 18-8	54	PP-5MCP-SEAL-W15	3	PP5 PUMP VALVE SHOE
14	SO-PP5M-L1MST	2	PP5M O-RING L3 DAMPER 024 N70	34	PP-5MCP-MBX150	2	M8 X 140 SGT CAP SCREW 18-8	55	PP-5MCP-SEAL-W15	3	PP5 PUMP VALVE
15	SO-PP5M-L1MST	1	PP5M O-RING L3 IN 040 N70	35	PP-5MCP-MBX150	2	M8 X 140 SGT CAP SCREW 18-8	56	PP-5MCP-SEAL-W15	3	PP5 VALVE STEVE STEPPED
16	PP-5MCP-LY1P	1	PP 5MCP LAYER 1	36	PP-5MCP-MBX150	2	M8 X 125 FLANGE NUT 18-8 SS	57	SO-PP5-AP	6	PP5 VALVE PLUG - 0103 N70
17	SO-PP5M-L1M	1	PP5M O-RING L3 OUT 045 N70	37	PP-5MCP-MBX150	2	PP5MCP 5CP PLUNGER STUD REV B	58	PP-5MCP-AP	6	PP5 VALVE PLUG - 0509 GROOVE
18	SO-PP5M-L1M	3	PP5M O-RING L3 CYLINDER 023 N70	38	PP-5MCP-MBX150	2	PP5MCP SLINGER WASHER LARGE REV A	59	PP-5MCP-AP	6	PP5 VALVE SPRING
19	PP-5M-KR3	1	PP5M RELIEF SCREW REV C	39	PP-5MCP-MBX150	2	CAT SCP KEYHOI E WASHER 4597 REV A	60	PP-5MCP-AP	6	PP5 VALVE CAGE
20	PP-5M-KR3	1	PP5M RELIEF NUT S-8	41	PP-5MCP-PG-1B50	3	PP5MCP 5CP PLUNGER TUBE 50% REV A	61	PP-5MCP-AP	6	

Remove all burrs and sharp edges, max radius 0.010"

Material											
Surface Finish											
Dimensions	Inches										
Tolerances	Do not scale	Isometric Projection									
SCALE: 1-10	8										

**SP5M 5CP Assembly 50% Rev D Exploded**

Contact: Spectra Watermakers  
 Phone: (415) 326-2780  
 E-mail: customerservice@spectrawatermakers.com  
 Dwg No: Size D Sht 1 of 1

## Parts I.D.

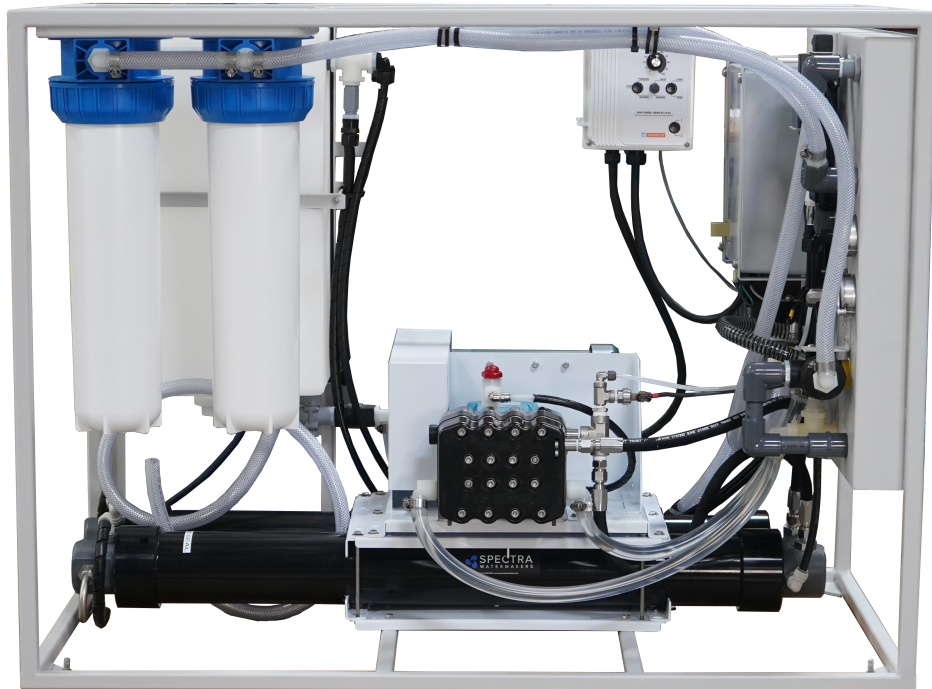

**Note:** The primary difference among the LB 1800 Framed unit, the LB 2800 Framed unit, and the LB 4000 Framed unit is the number of Pressure Vessels and Reverse Osmosis Membranes required to meet each units daily water output requirements. The LB 1800F contains two (2) pressure vessels and membranes, the LB 2800F contains three (3) pressure vessels and membranes, and the LB 4000F contains four (4) pressure vessels and membranes. The parts for every other sub assembly remain virtually the same. Consult your local certified Spectra Watermakers distributor

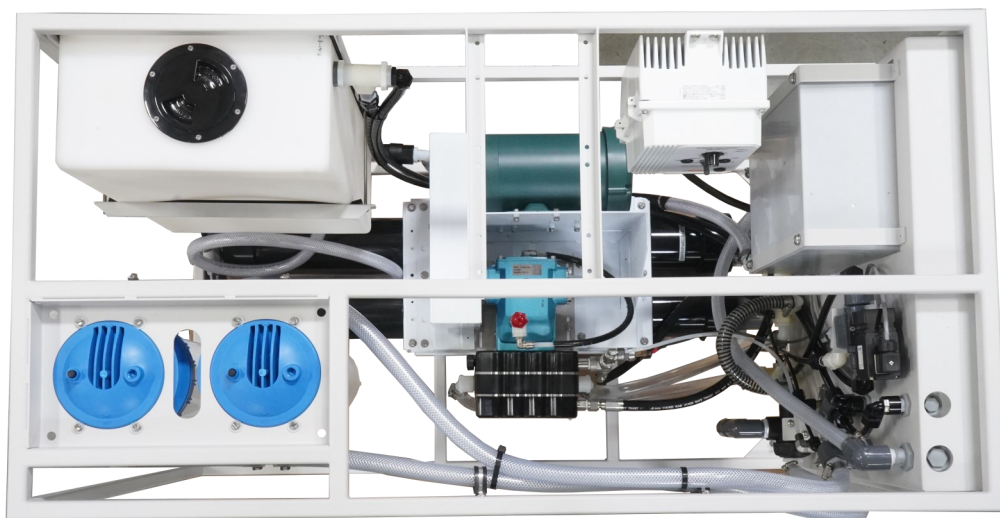

# Parts I.D.

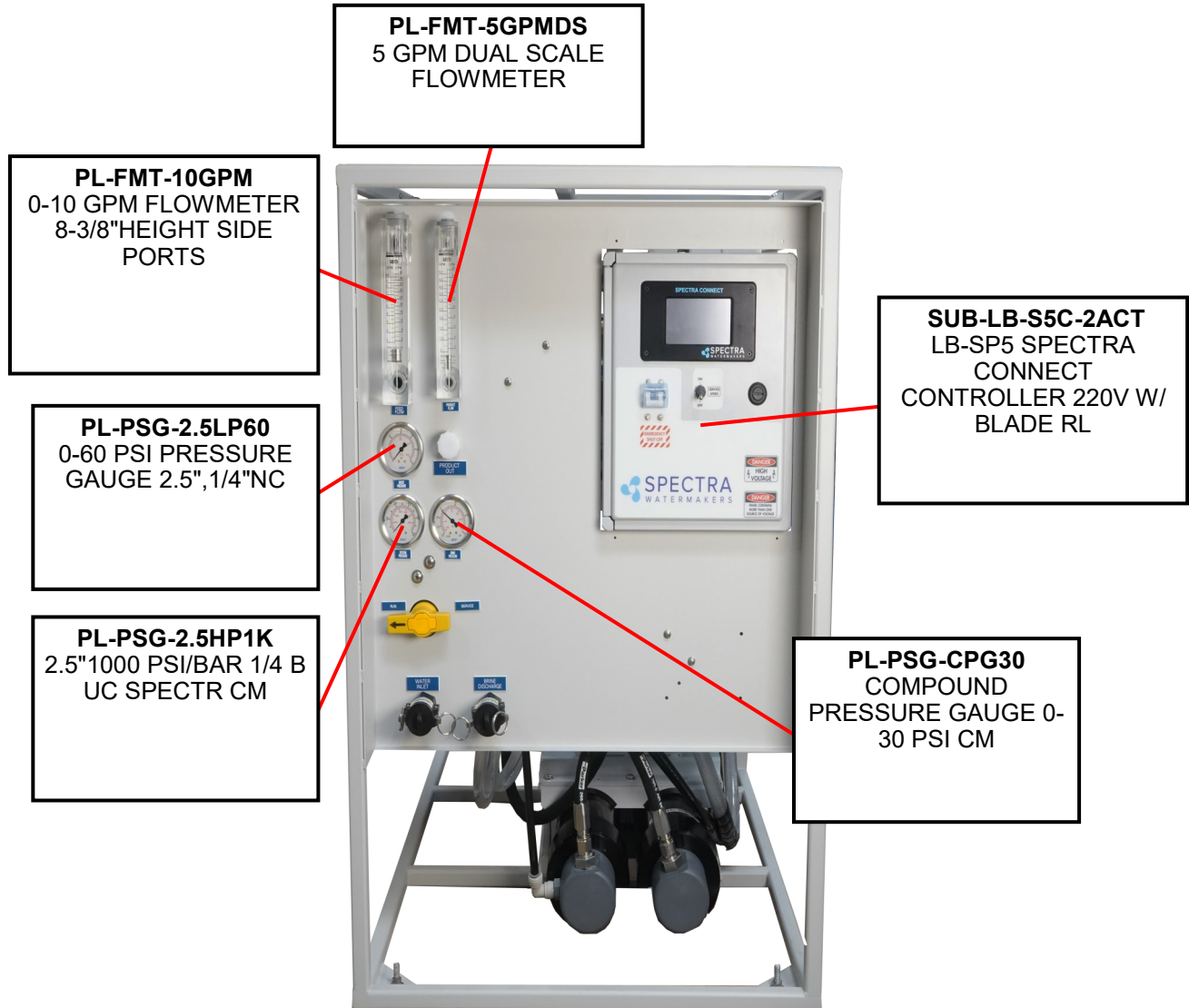

## Parts I.D.

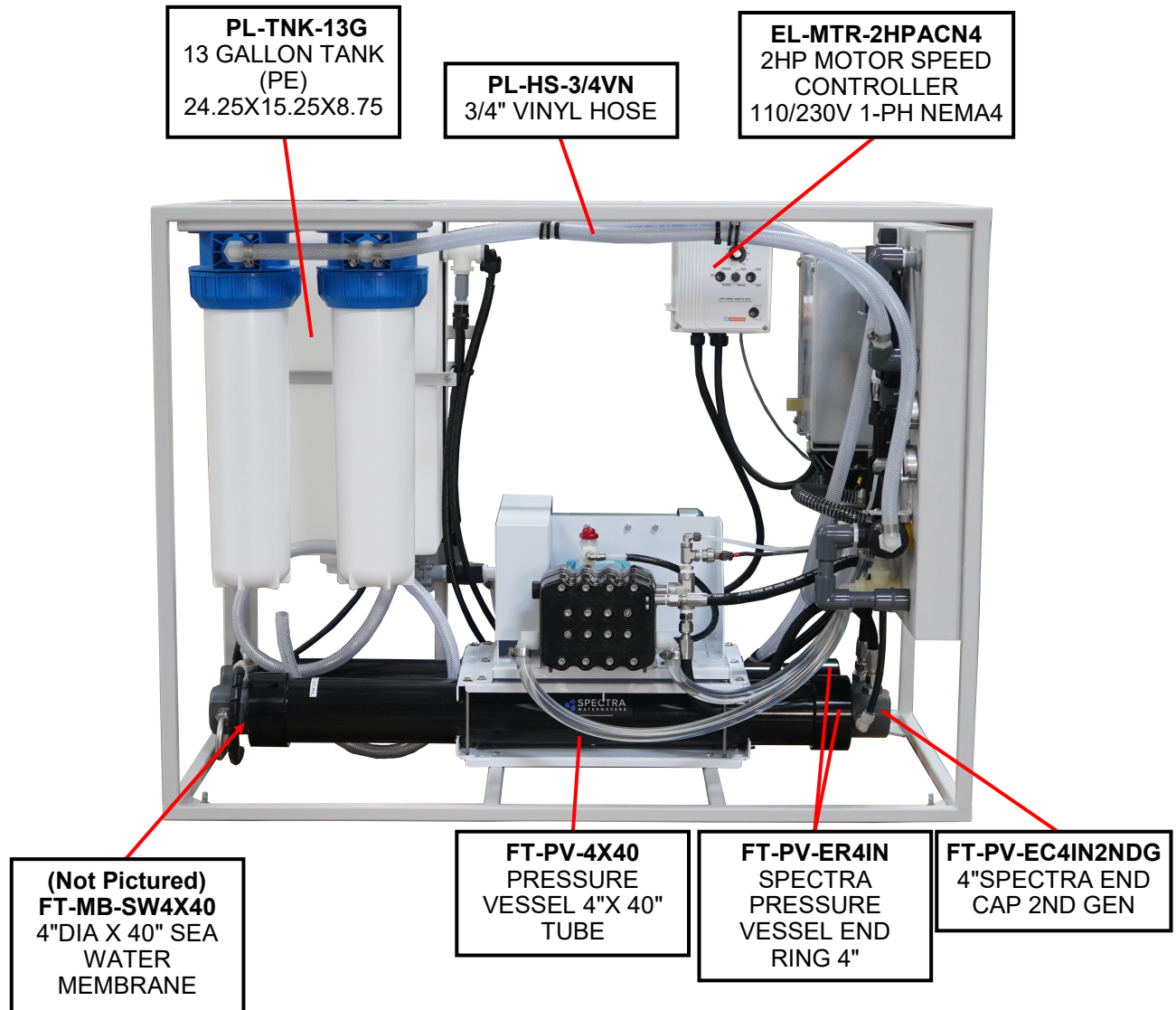



# Parts I.D.

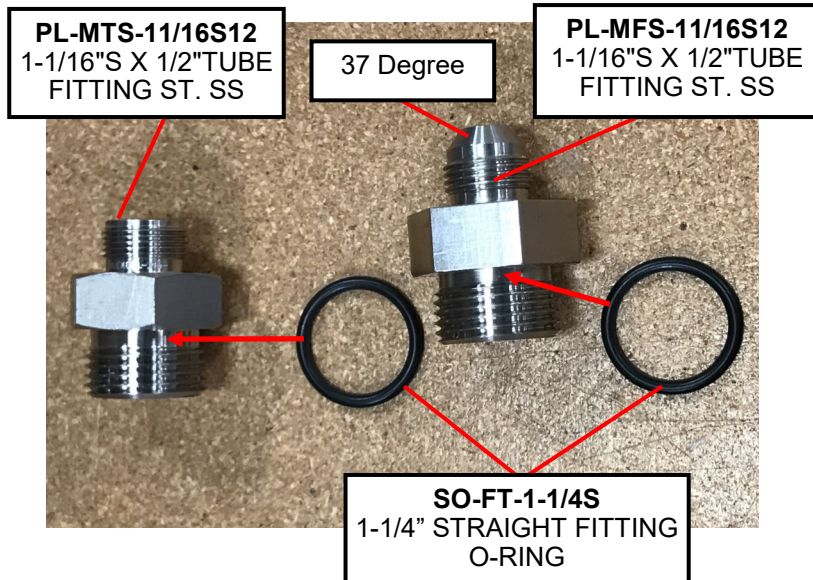
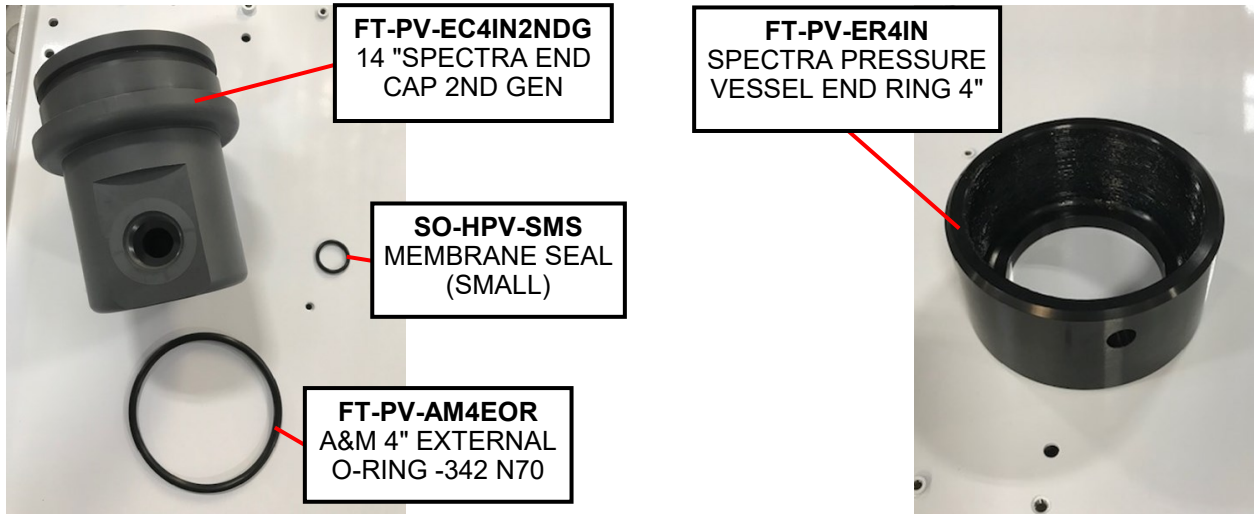
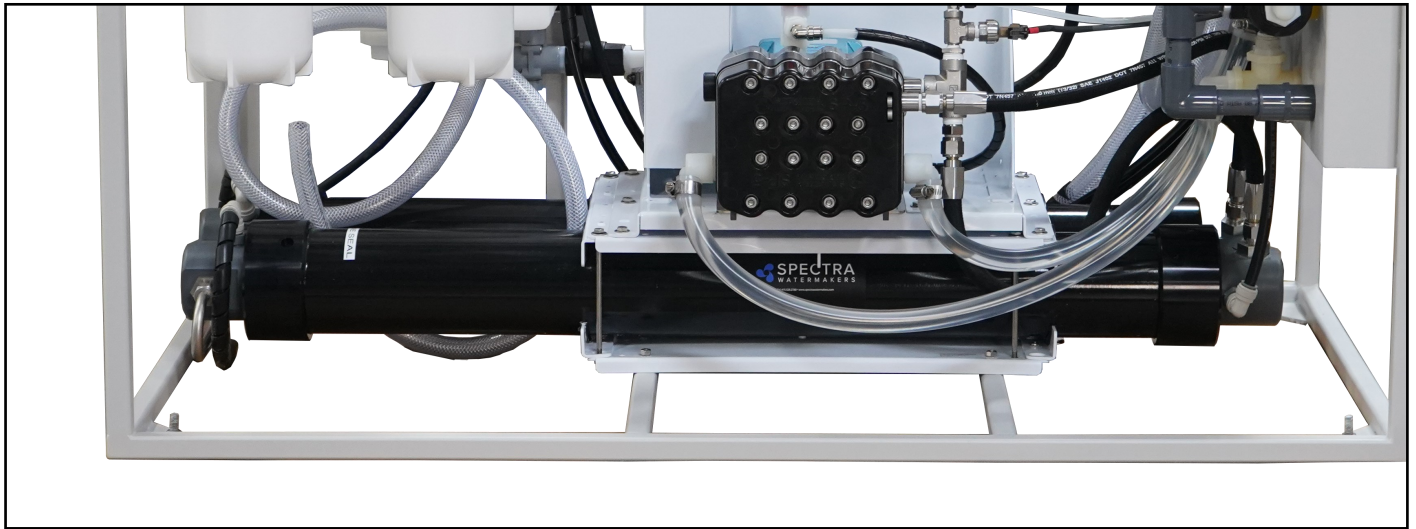

# Parts I.D.

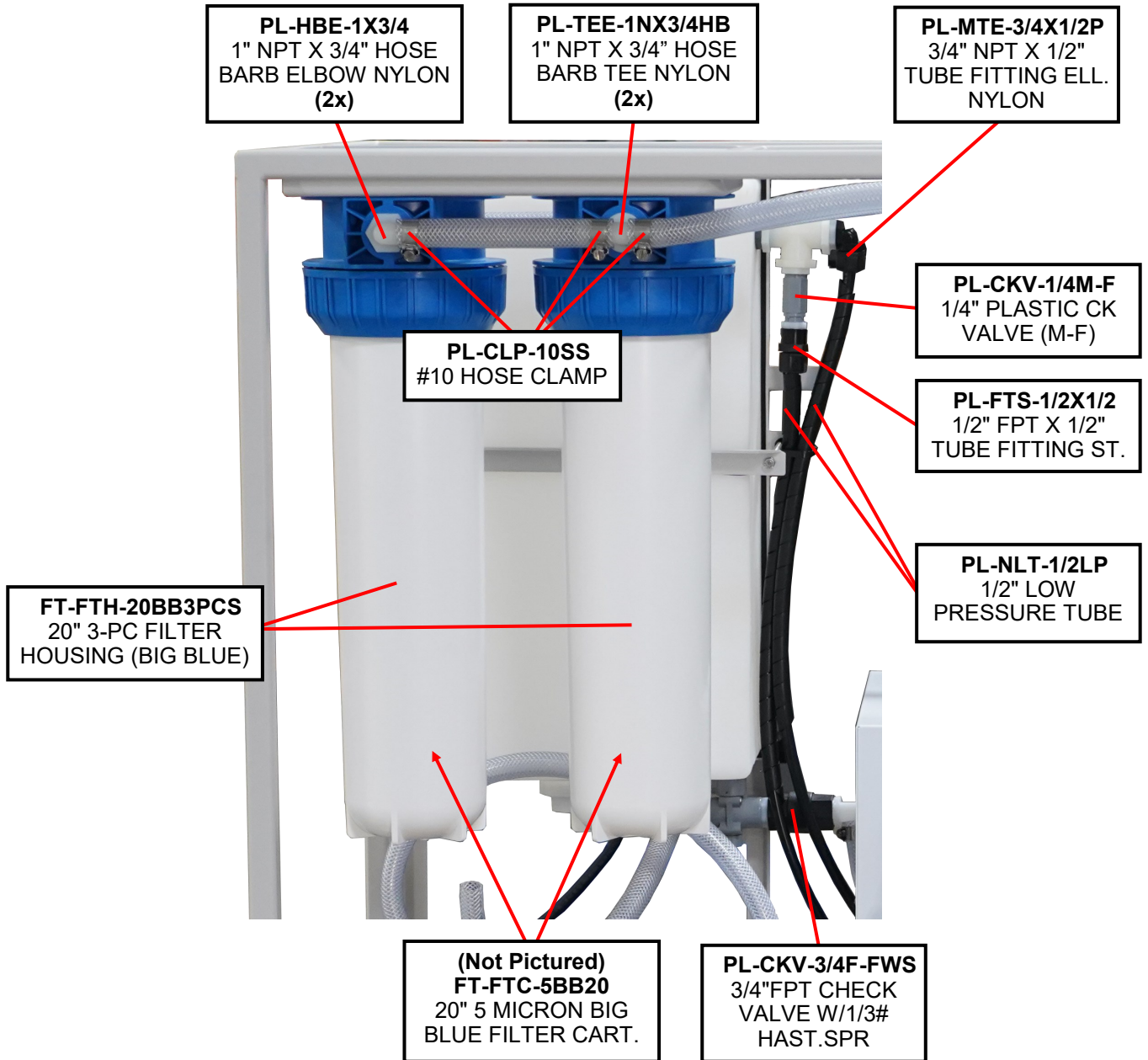

## Parts I.D.

**EL-MTR-2HP220AC**  
2 H.P. MOTOR 220 AC  
3 PH, 1750 RPM  
HAST.SPR

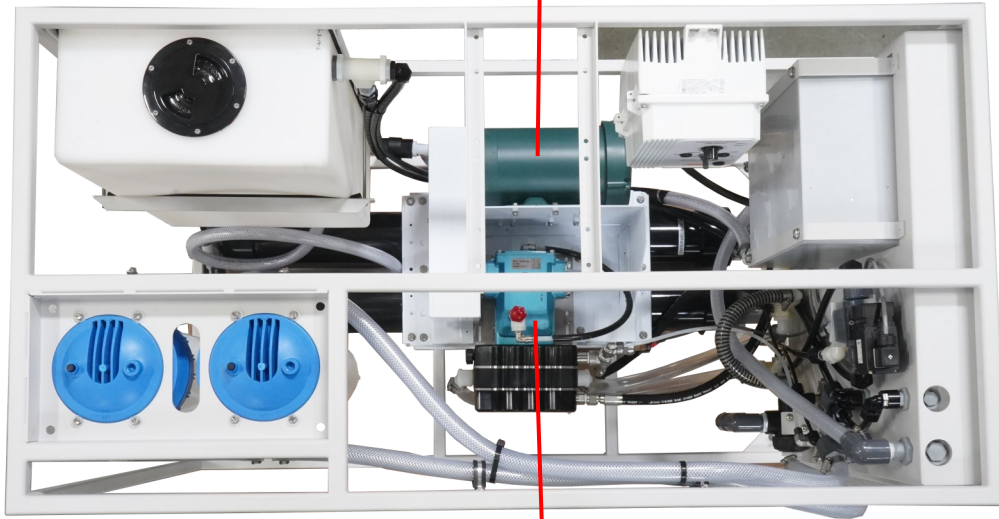

**SPP5MCP-50**  
SPP5MCP-50 PUMP  
ASSEMBLY

## Parts I.D.

**EL-MTR-2HP220AC**  
2 H.P. MOTOR 220  
AC 3 PH, 1750 RPM

**PP-5-BD-DV5/8AL**  
SPP5 DRIVER 18HB100  
5/8DIA 3/16K HD

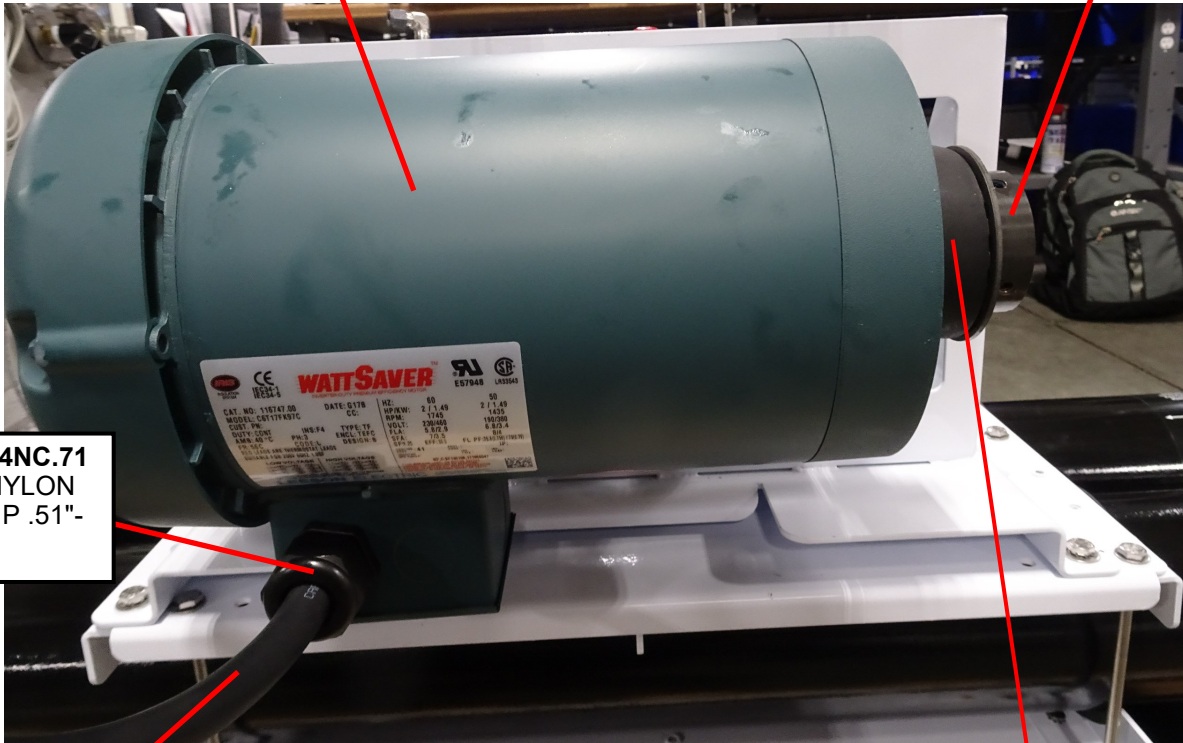

**EL-MCD-3/4NC.71**  
3/4"NPT NYLON  
CORD GRIP .51"-  
.71"

**EL-CBL-14X4PC**  
14AWG X 4C ROUND  
POWER CABLE  
(3')

**EL-RT-10L16-14**  
16-14 AWG X #10 RING  
TERMINAL  
Located on other end of  
Power Cable  
(4x)

**PP-5-BD-BLT300H**  
SPP5 BELT 300H100

# Parts I.D.

**Assembly #1**  
Float Valve Assembly  
(Inside tank)

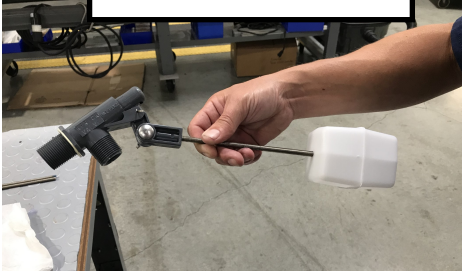

**Assembly #2**  
Flush Tank Input



**Assembly #3**  
Flush Tank Output

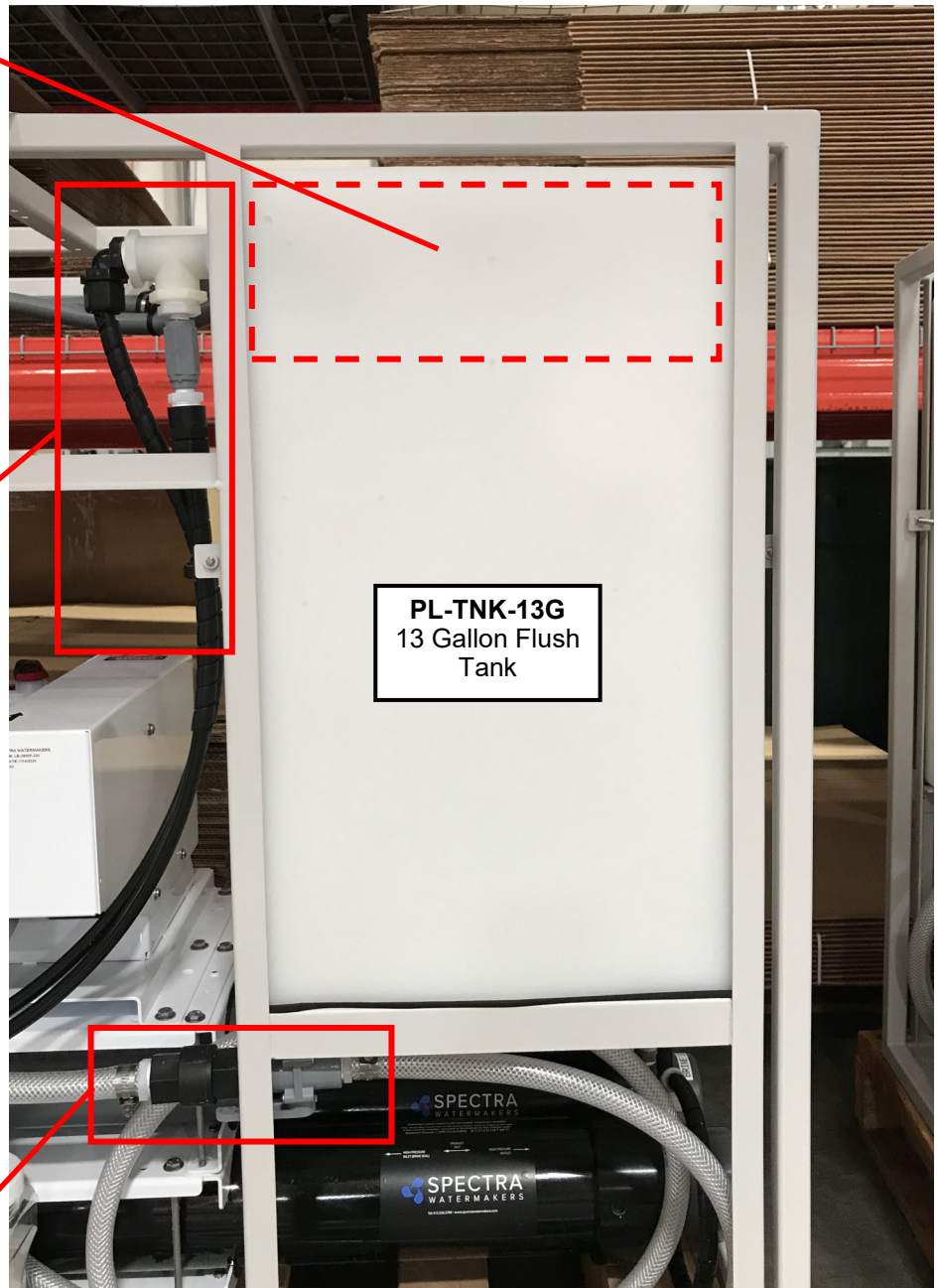
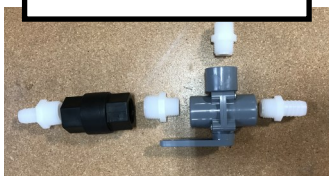

See page 70 and 71 for parts I.D.

# Parts I.D.

**Assembly #1**  
Float Valve Assembly  
(Inside tank)

**PL-VLV-FV**  
3/4" PVC FLOAT VALVE

**PL-VLV-F**  
POLYPROPYLENE FLOAT

**HD-TR-1/4-20**  
1/4"-20 THREAD ROD  
(7")

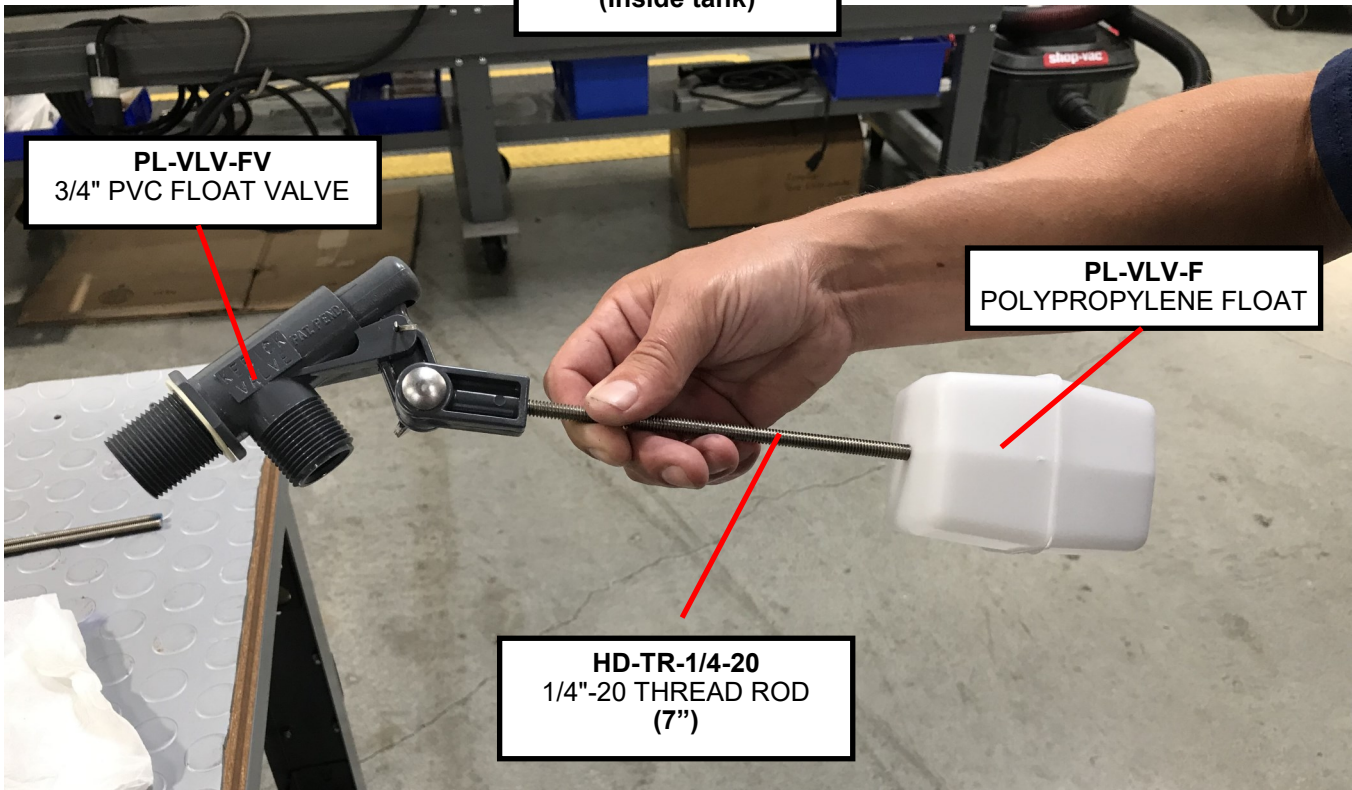

# Parts I.D.

## Assembly #2 Flush Tank Input

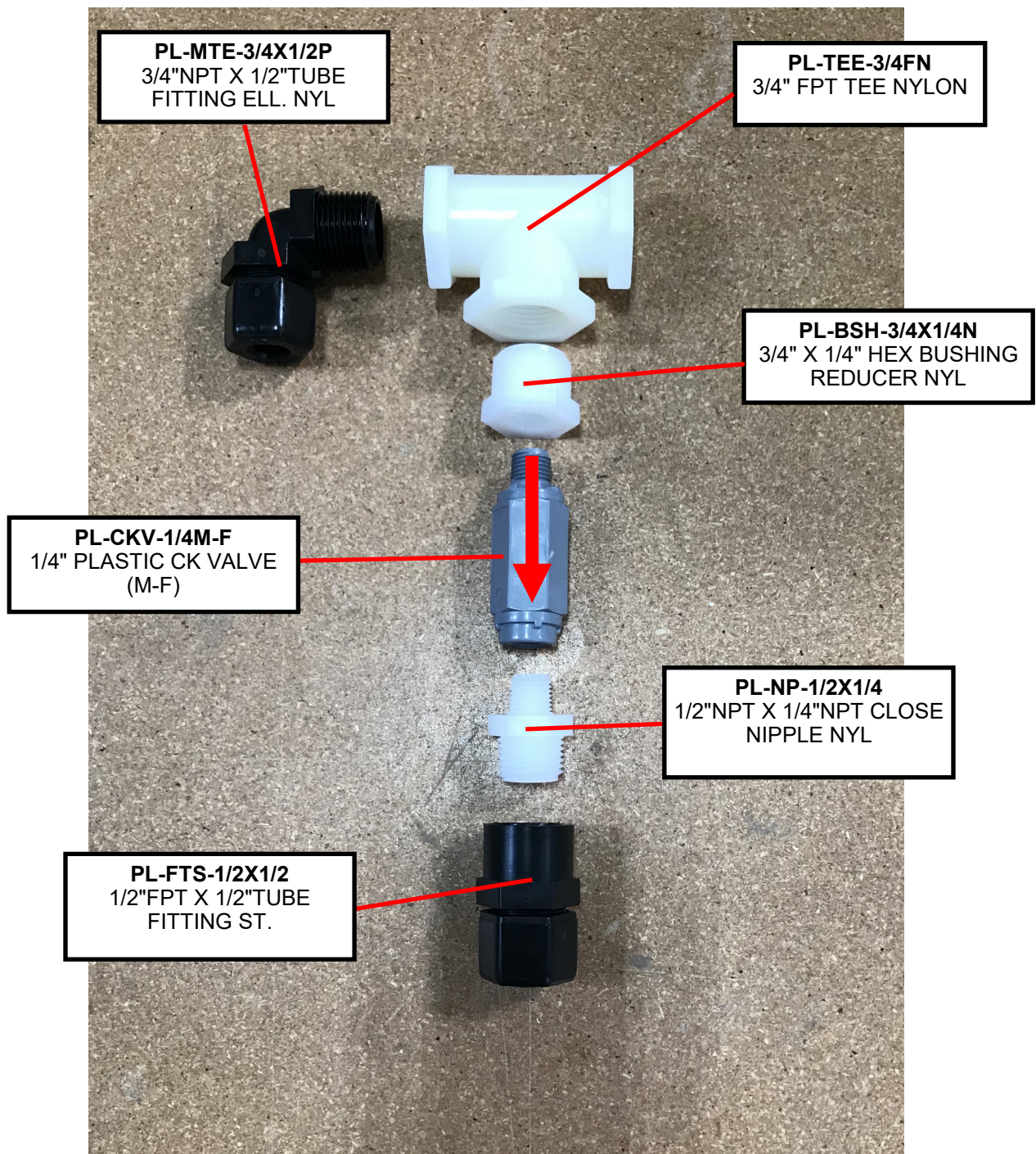

**Note: Use Teflon Tape to wrap all threaded plumbing fittings.**

## Parts I.D.

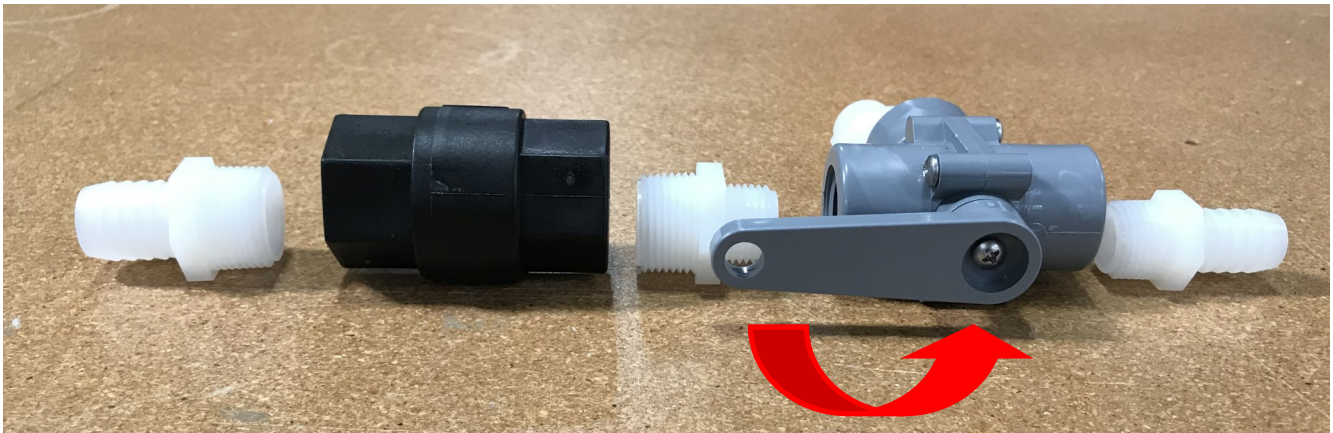
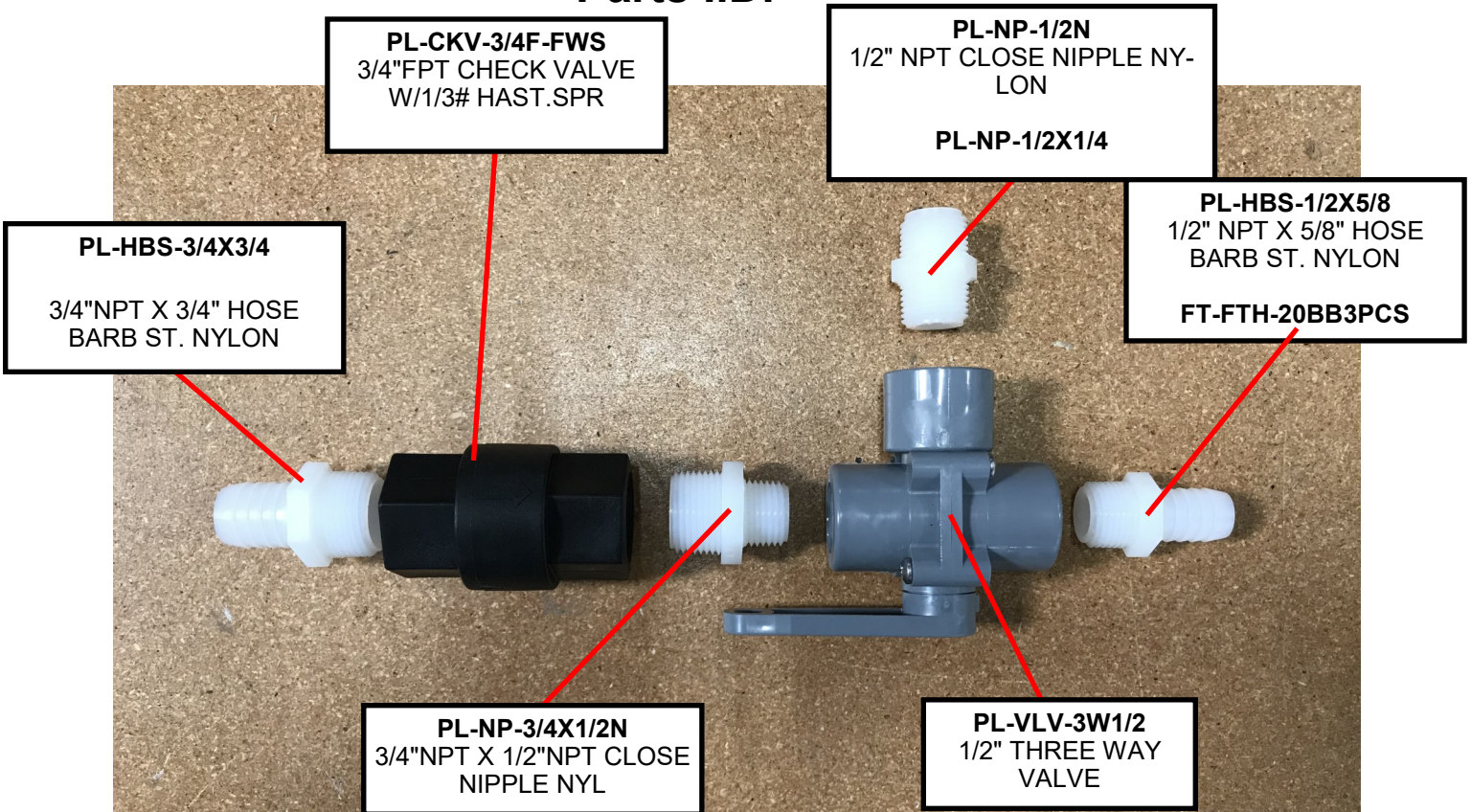

**Note:** The handle on the three way valve must swing away from the frame when installed.



# Parts I.D.

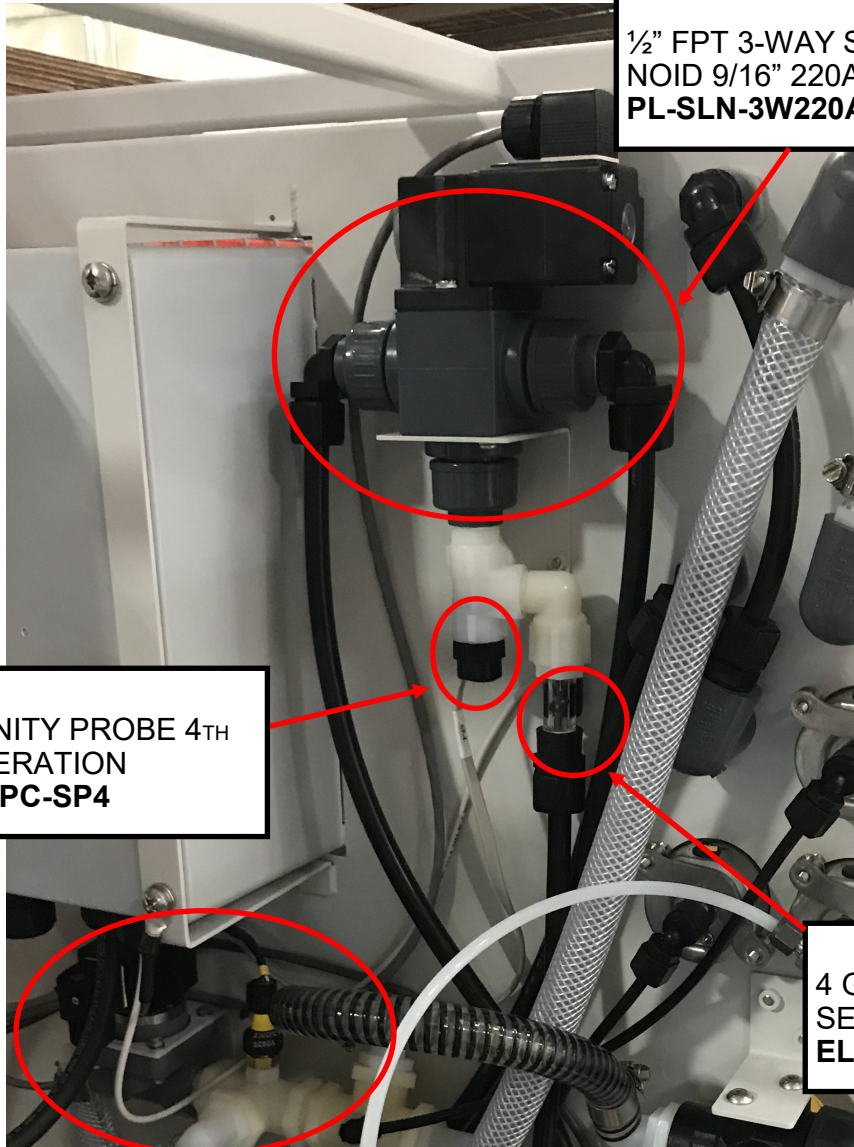

1/2" FPT 3-WAY SOLE-  
NOID 9/16" 220AC  
PL-SLN-3W220AC

SALINITY PROBE 4<sup>TH</sup>  
GENERATION  
EL-MPC-SP4

4 GPM INLINE FLOW  
SENSOR  
EL-SSR-IFM4GPM

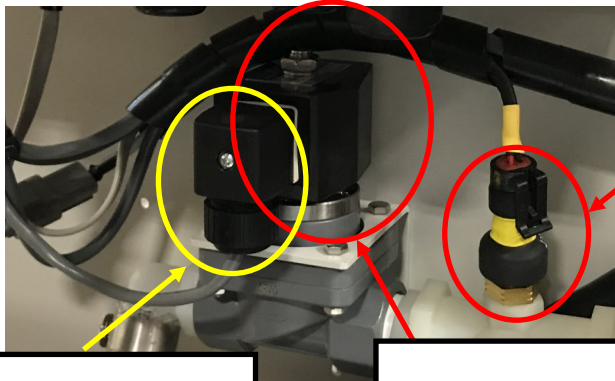

Pressure Transducer  
150  
EL-SSR-150

Burkert Solenoid valve  
connection  
EL-TM-BKVC

3/4" FPT 1-way SLN VLV  
24V PVC Inlet  
PL-SLN-3/4F1W24

# Parts I.D.

